

# Installation and Operating Instructions



# POOLcontrol<sup>®</sup>-45 *exclusiv*

## Filter control unit with built-in level control and LAN port

Part no. 310.000.0580



### Compatible pumps

- 230V single-phase pump  
(rated current up to 8A)
- 400V three-phase pump  
(rated current up to 8A)
- Speck ECO-Touch-Pro pump
- Speck Badu-90-ECO-VS pump
- Speck Badu-90-ECO-Motion pump
- Pentair IntelliFlo pump
- Pentair SuperFlo pump
- Zodiac FloPro VS pump
- UWE PMM pump

## Technical data

Dimensions:	300mm x 285mm x 85mm	
Operating voltage:	3/N/PE 400V/230V 50Hz	
Power consumption of control unit:	approx.5VA (depends on operating mode)	
Switching capacity:	Pump:	max. 8A / 3.0 kW (AC3)
	Heater:	max. 3A / 0.4 kW (AC3)
	Dosing system:	max. 3A / 0.4 kW (AC3)
	Auxiliary output:	max. 3A / 0.4 kW (AC3)
Degree of protection:	IP 40	
Level sensors:	12V Safety Extra Low Voltage (SELV)	
Ambient temperature:	0-40°C	
Air humidity:	0-95% non-condensing	
Memory card:	Micro SD	
Internet port:	LAN	

# Contents

<b>Technical data .....</b>	<b>1</b>
<b>Contents .....</b>	<b>2</b>
<b>Function .....</b>	<b>5</b>
<b>Installation .....</b>	<b>5</b>
<b>Fuses.....</b>	<b>6</b>
<b>Electrical connection .....</b>	<b>6</b>
Low-voltage lines.....	6
Connecting the power supply for a 400V three-phase pump.....	6
Connecting the power supply for a 230V single-phase pump.....	7
Connecting the power supply for a 230V pump (with electronic motor protection enabled).....	7
Connecting the power supply for a Speck ECO-Touch-Pro pump.....	7
Connecting the power supply for a Speck ECO-VS pump.....	7
Connecting the power supply for a Speck Badu-90-ECO-Motion pump.....	8
Connecting the power supply for a Zodiac FloPro VS pump .....	8
Connecting the power supply for a Pentair IntelliFlo pump.....	8
Connecting the power supply for a Pentair SuperFlo VS pump.....	9
Connecting the power supply for a UWE PMM pump.....	9
Connecting the heating system .....	9
Auxiliary input .....	9
Connecting the EUROTRONIK-10 for backwashing using a 6-way multiport valve .....	9
Operating the PC-45 exclusiv without a EUROTRONIK-10 unit.....	9
Connecting the slide valves for backwashing .....	10
Connecting the cover limit-switch.....	10
Connecting a flow sensor .....	10
Connecting the dosing equipment.....	10
Connecting a fault indicator.....	11
Connecting a main drain valve (ECO valve) .....	11
Connecting a pressure switch .....	11
Connecting a drain-monitoring switch .....	11
Connecting a shut-off valve (interlock for the 2nd filter).....	12
<b>Temperature sensor.....</b>	<b>12</b>
Pool temperature sensor .....	12
Solar temperature sensor.....	12
Air temperature sensor.....	12
<b>Level control.....</b>	<b>13</b>
Overflow pool with spillway .....	13
Operation with 6 probes .....	13
Operation with 5 probes .....	14

How level control works for balancing tanks .....	14
Pool with skimmer .....	15
Level measurement in the standpipe .....	15
Use without level control .....	15
Solenoid valve for topping up the water level.....	15
<b>Display .....</b>	<b>16</b>
<b>Operation .....</b>	<b>16</b>
Switching on the PC-45 exclusiv .....	16
Switching off the PC-45 exclusiv .....	17
Operating mode selection .....	17
Child safety lock .....	17
Pro mode (Service engineer level) .....	17
Heater settings .....	18
Setting the water temperature.....	18
Temperature reduction in Eco mode.....	18
Switching the heating on/off .....	18
Frost protection .....	18
Settings for the filtration system .....	18
Automatic – Continuous running – Off .....	19
Programming the filtration timer .....	19
Deleting a timer setting .....	19
Checking the timer settings.....	20
Setting the ECO filtration times .....	20
Automatic – Continuous running – Off .....	21
Entering, editing and deleting ECO timer settings .....	21
Backwash using slide valves.....	21
Manual backwash .....	21
Programming the backwash timer settings.....	21
Setting up Party mode.....	22
Fault indicators / Information page .....	23
“Pump disabled” fault indicator .....	23
Resetting any fault indicators .....	23
Log .....	23
Operating hours counter .....	23
Acoustic alarm.....	23
<b>Service settings.....</b>	<b>24</b>
Set the date and time .....	24
Add a new device .....	24
Perform factory reset.....	24
Network settings.....	24
Alarm settings .....	24
Set the level-control parameters .....	24
Set motor protection.....	24
Set the pump startup time .....	24
Set the backwash duration.....	24
Set the rinse duration .....	24
Set the temperature-control parameters .....	24
<b>Configuring the control unit.....</b>	<b>25</b>
<b>Pro mode .....</b>	<b>25</b>

Configuring the level control .....	25
Configuring the filtration pump .....	25
Configuring the heating .....	26
Setting the heating parameters .....	26
Configuring the solar heating .....	26
Setting the heating parameters .....	26
Configuring the air temperature sensor .....	26
Frost protection .....	26
Configuring the backwashing .....	26
Setting the backwash period (slide valve) .....	26
Setting the rinse period (slide valve) .....	26
Configuring the main drain valve .....	26
<b>Connecting a Filter-Control plus to the PC-45 exclusiv .....</b>	<b>27</b>
<b>Establishing communication between a PC-45 exclusiv and a Filter-Control plus.....</b>	<b>28</b>
Adding a second filter control panel .....	28
Disconnecting the <i>Filter-Control plus</i> from the <i>PC-45 exclusiv</i> .....	28
Operation (2nd filter) .....	29
Home screen.....	29
Information page (2 filters) .....	29
Service functions (2 filters).....	30
Alarm settings for the 2nd filter .....	30
Service settings.....	30
<b>Configuring two filtration systems .....</b>	<b>30</b>
<b>Internet connection.....</b>	<b>32</b>
Using the osf communication server .....	32
<b>Communication server for pool owners .....</b>	<b>33</b>
Registering a new device with the server .....	33
<b>Communication server for pool installers .....</b>	<b>35</b>
Registering a new control unit with the server .....	35
<b>Communication server with technical view .....</b>	<b>37</b>
Registering a new device with the server .....	37
<b>Changing the PIN (password) .....</b>	<b>38</b>
Assigning a new PIN .....	39
<b>Naming the unit.....</b>	<b>39</b>
<b>Entering an e-mail address .....</b>	<b>39</b>
Entering an e-mail address .....	39
Assigning a name.....	39
<b>Update .....</b>	<b>40</b>
Checking for updates .....	40
<b>Interfacing with building automation systems .....</b>	<b>41</b>
<b>Wiring diagram .....</b>	<b>44</b>

## Function

The **OSI** PC-45 exclusiv control unit lets you time the on/off cycles of a filtration pump based on a user-programmable daily or weekly schedule. A 400V three-phase pump, a 230V single-phase pump or a variable-speed pump may be used as the filtration pump (see wiring diagrams). When using a 3-phase filtration pump, a 3-phase electronic motor protection device protects the pump from overload (current range has continuous adjustment up to 8A).

The unit can be combined with a "Filter-Control plus" control unit to control an additional filtration system including backwashing.

Backwashing can be performed using a 6-way multiport valve and installed EUROTRONIK-10 controller or using slide valves, and launched either manually or at a specific time or pressure.

The built-in level control is designed for use with overflow pools with spillway (balancing tank) and for skimmer pools.

While the filtration pump is running, the swimming pool heater is controlled by the electronic temperature controller. During pauses in filtration, the heating is automatically switched off by the internal interlock. The required water temperature for the swimming pool can be set on the touchscreen display. The heating can also be switched off from here. A live contact (terminal U2) and volt-free floating contacts (terminals 17&18) are available for connecting the heating system. Terminals are provided for connecting an **OSI** solar actuator when operating with solar absorbers that carry a direct flow of water from the pool. This control unit is not intended for use with other types of solar collectors. The absorber temperature must not exceed 80°C at the temperature sensor.

Terminals for connecting level sensors can be used for convenient automatic control of the water level in the swimming pool. There are also terminals for connecting a flow sensor or a pressure switch, and for a winding protection switch. This provides additional protection for the filtration pump against potential damage from running the filtration system without water.

Spare terminals are available for connecting additional devices. Terminal U3 (dosing equipment) carries 230 V only while filtration is running, but is de-energized outside filtration times. Terminals 20&21 (dosing equipment) are volt-free floating contacts for custom use. The relay contact between terminals 20 and 21 is closed while filtration is running, and open outside filtration times. This contact is rated for a maximum voltage of 230V and a maximum power of 400W (cos  $\varphi$ 0.6).

Terminals 24&25 are volt-free floating contacts that can be used for fault indication.

The connecting terminals for the winding protection switch (terminals 1 and 2) are designed for connecting a thermal winding protection switch built into the filter-pump motor winding. If this switch opens, e.g. as a result of the motor winding getting too hot, the filtration pump is switched off automatically along with the heating and dosing equipment. Once the winding protection switch closes again after the motor winding has cooled down, the units automatically switch back on. There is no need for a manual reset. The connecting terminals for the winding protection switch carry 230V.

The motor protection device can only be used with 400V/50Hz filtration pumps connected to terminals U1/V1/W1. Motor protection is not active if you have selected a configuration using a variable speed pump or a 230V pump.

## Installation

The swimming pool must be designed and built to prevent consequential damage resulting from a potential technical fault, power failure or a faulty unit.

## Fuses

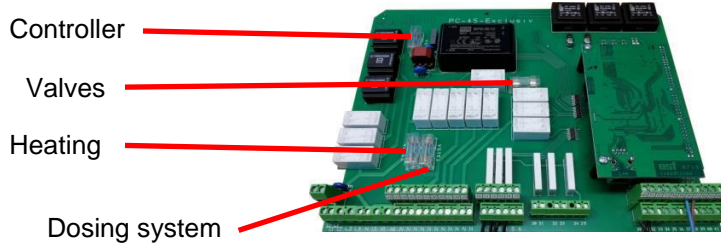

The electronic controller is protected by a 0.5A microfuse located on the printed circuit board inside the control unit. A separate 3.15A microfuse is provided for each of the following outputs: heating, dosing equipment and valves. The customer must fit mains fuses of maximum rating 16A to provide short-circuit protection for the filtration pump.

## Electrical connection

The control unit must be mounted such that it is protected from moisture in accordance with its degree of protection. The ambient temperature must lie between 0° C and + 40° C and should vary as little as possible. The relative humidity at the installation position must not exceed 95% and there must not be any condensation. Avoid exposing the unit to direct heat or sunlight.

The power supply for the unit must be provided via an all-pole disconnection switch with a minimum contact gap of 3mm and via a residual-current circuit breaker with a fault current  $I_{FN}$  of  $\leq 30\text{mA}$ . When using variable-frequency drives and variable speed pumps, the residual-current circuit breakers stipulated for these devices must be used and the relevant regulations observed. **Always disconnect the unit from the power supply before opening the case. All electrical wiring and calibration and servicing work must be performed solely by an approved electrician. The attached wiring diagrams and all applicable safety regulations must be observed.**

The switching outputs of the PC-45 exclusiv are not intended as a voltage supply for variable frequency drives. Please refer to the relevant wiring diagrams in these operating instructions.

### Low-voltage lines

Low-voltage lines must not be laid along with three-phase or AC power cables in the same cable conduit. In general, always avoid routing low-voltage lines close to three-phase or AC power cables.

### Connecting the power supply for a 400V three-phase pump

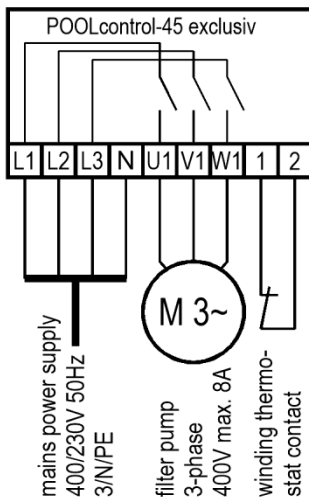

The factory-inserted link between the two terminals 1 and 2 must be removed when connecting a pump fitted with a winding protection switch. If the pump does not have a winding protection switch, the link must remain screwed in place. These terminals are live and carry a mains voltage!

The 3-phase pump option must be selected for the filtration pump in the configuration menu.

The pump is monitored by the electronic motor protection device. To provide protection, the trip current for the motor protector must be set to the rated current of the pump (specified on the type plate).

### Connecting the power supply for a 230V single-phase pump

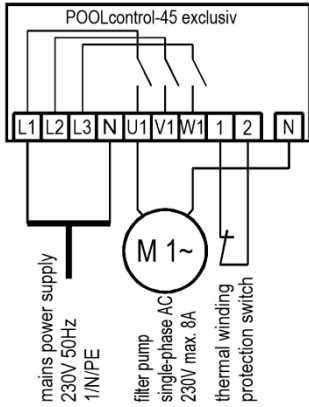

The factory-inserted link between the two terminals 1 and 2 must be removed when connecting a pump fitted with a winding protection switch. If the pump does not have a winding protection switch, the link must remain screwed in place. These terminals are live and carry a mains voltage!

The **single-phase pump** option must be selected for the filtration pump in the configuration menu.

In this operating mode, the pump is not monitored by the electronic motor protection device.

### Connecting the power supply for a 230V pump (with electronic motor protection enabled)

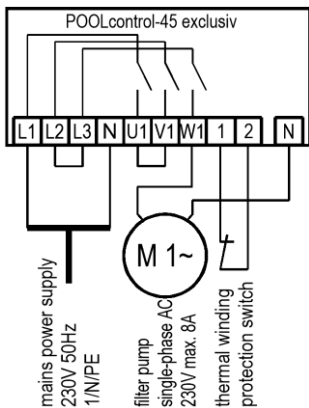

If a 230V pump is meant to be monitored by the electronic motor protection device, the **3-phase pump** option must be selected for the filtration pump. The trip current for the motor protector must be set to the rated current of the pump (specified on the type plate). For the electronic motor protection to work correctly, the electrical power to the motor must pass via all three switching contacts of the filter control unit (place link between terminals L2 and L3 and between U1 and V1; connect pump to W1).

The factory-inserted link between the two terminals 1 and 2 must be removed when connecting a pump fitted with a winding protection switch. If the pump does not have a winding protection switch, the link must remain screwed in place. These terminals are live and carry a mains voltage!

### Connecting the power supply for a Speck ECO-Touch-Pro pump

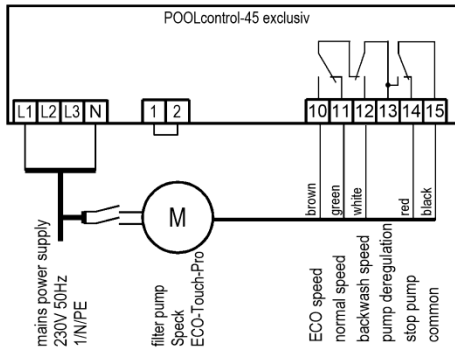

A Speck ECO-Touch-Pro pump can be connected directly to the PC-45 exclusiv unit. Connect the speed controller to terminals 10-15.

The mains power supply to the pump must be provided separately, not via the PC-45 exclusiv.

There must be a link inserted between the two terminals 1 and 2 (winding protection switch).

The **var. speed pump** option must be selected for the filtration pump in the configuration menu.

Always refer to the operating instructions for the pump.

### Connecting the power supply for a Speck ECO-VS pump

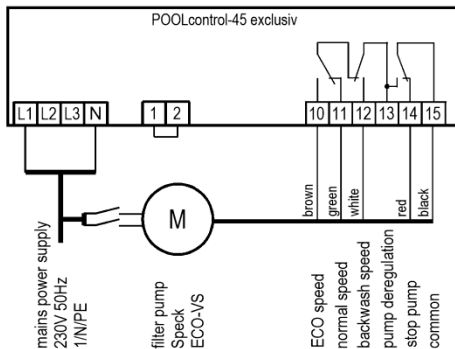

A Speck ECO-VS pump can be connected directly to the PC-45 exclusiv unit. Connect the speed controller to terminals 10-15.

The mains power supply to the pump must be provided separately, not via the PC-45 exclusiv.

There must be a link inserted between the two terminals 1 and 2 (winding protection switch).

The **var. speed pump** option must be selected for the filtration pump in the configuration menu.

Always refer to the operating instructions for the pump.

The digital inputs must be set at the pump to "dl" in the pump setup menu.

### Connecting the power supply for a Speck Badu-90-ECO-Motion pump

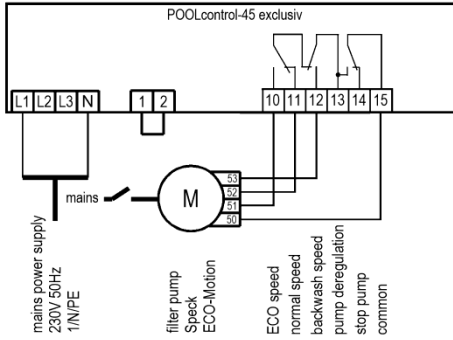

A Speck Badu-90-ECO-Motion pump can be connected directly to the PC-45 exclusiv unit. Connect the speed controller to terminals 10-15.

The mains power supply to the pump must be provided separately, not via the PC-45 exclusiv.

There must be a link inserted between the two terminals 1 and 2 (winding protection switch).

The var. speed pump option must be selected for the filtration pump in the configuration menu.

Always refer to the operating instructions for the pump.

In the Setup menu on the pump, the external control must be enabled for "digital fixed speeds" with the signal type "continuous signal". The speeds required for ECO mode, normal mode and backwash mode must be set for the speeds N1, N2 and N3.

### Connecting the power supply for a Zodiac FloPro VS pump

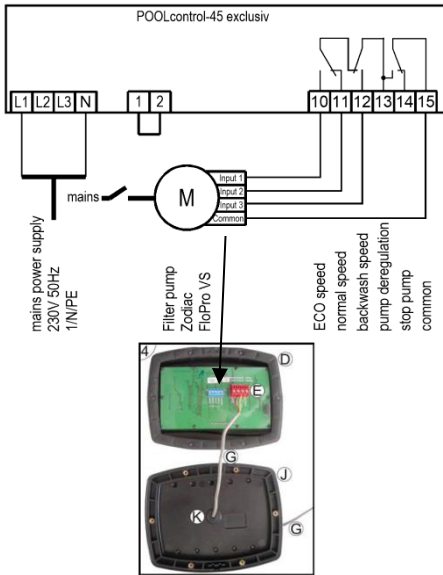

A Zodiac FloPro VS pump can be connected directly to the PC-45 exclusiv unit. Connect the speed controller to terminals 10-15.

The mains power supply to the pump must be provided separately, not via the PC-45 exclusiv.

There must be a link inserted between the two terminals 1 and 2 (winding protection switch).

The var. speed pump option must be selected for the filtration pump in the configuration menu.

Always refer to the operating instructions for the pump.

On the pump, the speed controller must be connected to the designated terminals on the back of the user interface. The speeds required for ECO mode (level 1), normal mode (level 2) and backwash mode (level 3) must be assigned to speed levels 1 to 3.

### Connecting the power supply for a Pentair IntelliFlo pump

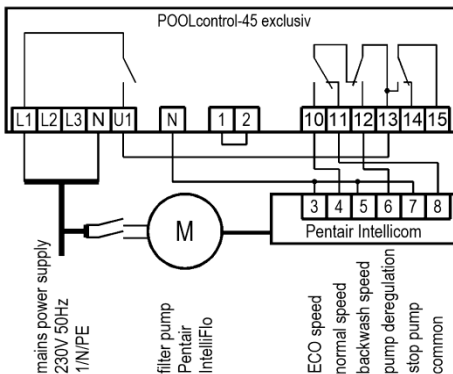

An IntelliFlo pump can be controlled by the PC-45 exclusiv using the Pentair Intellicom controller.

The mains power supply to the pump must be provided separately, not via the PC-45 exclusiv.

There must be a link inserted between the two terminals 1 and 2 (winding protection switch).

The var. speed pump option must be selected for the filtration pump in the configuration menu.

Always refer to the operating instructions for the pump.



### Connecting the power supply for a Pentair SuperFlo VS pump

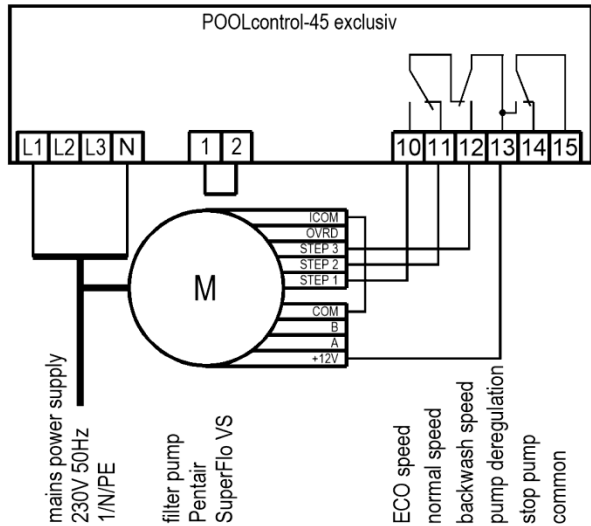

A SuperFlo VS pump can be controlled by the PC-45 exclusiv.

The mains power supply to the pump must be provided separately, not via the PC-45 exclusiv.

There must be a link inserted between the two terminals 1 and 2 (winding protection switch).

The var. speed pump option must be selected for the filtration pump in the configuration menu.

Always refer to the operating instructions for the pump.

### Connecting the power supply for a UWE PMM pump

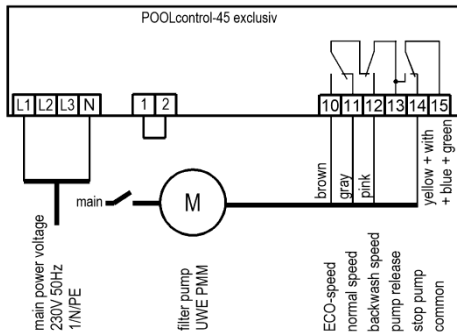

A UWE PMM pump can be controlled by the PC-45 exclusiv.

The mains power supply to the pump must be provided separately, not via the PC-45 exclusiv.

There must be a link inserted between the two terminals 1 and 2 (winding protection switch).

The var. speed pump option must be selected for the filtration pump in the configuration menu.

Always refer to the operating instructions for the pump.

### Connecting the heating system

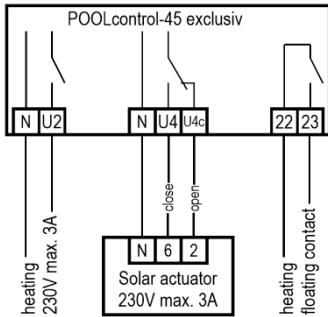

The pool heating can be connected to terminal U2. This output supplies 230V and is rated for a maximum load of 3A.

In addition, a floating contact is provided at terminals 22+23 (e.g. for controlling the boiler).

An **ISI** 230V solar actuator can be connected to terminals U4 and U4c for operating the solar heating. When solar heating is operating, the mains voltage is applied to terminal U4 and no voltage is applied to terminal U4c. When solar heating is not actuated, no voltage is applied to terminal U4 and the mains voltage appears at terminal U4c.

### Auxiliary input

The auxiliary input has no function in this version.

### Connecting the EUROTRONIK-10 for backwashing using a 6-way multiport valve

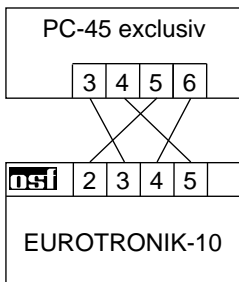

A 4-wire connection (12V Safety Extra Low Voltage) is required for connecting the EUROTRONIK-10. Ensure that the wires are connected to the correct terminal at each end. The EUROTRONIK-10 additionally requires a separate power supply. The backwash times are programmed on the EUROTRONIK-10.

### Operating the PC-45 exclusiv without a EUROTRONIK-10 unit

If the PC-45 exclusiv is intended to be operated without a EUROTRONIK-10 unit, terminals 3 and 4 must be connected together (with a link).

### Connecting the slide valves for backwashing

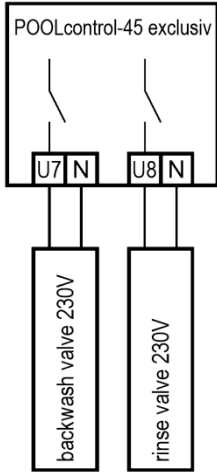

A 230V slide valve for the backwash function can be connected to terminals U7 and N.  
 A 230V slide valve for the rinsing function can be connected to terminals U8 and N.  
 Both valves are controlled by the internal backwash controller.  
 The heating and dosing systems are disabled during the backwash and rinsing operation.

### Connecting the cover limit-switch

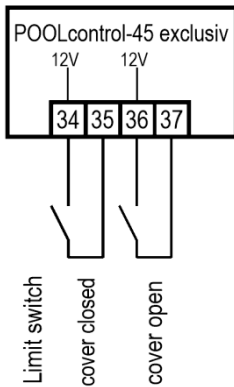

A limit switch for the swimming-pool cover can be connected to terminals 34 and 35.  
 This switch automatically starts ECO mode when the cover is closed.  
 A limit switch for the pool cover can be connected to terminals 36 and 37. The switch has no function in this version.

The terminals carry a safety extra low voltage.

### Connecting a flow sensor

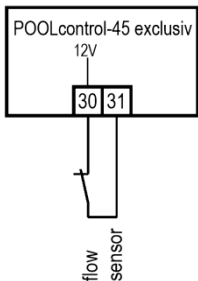

A flow sensor or a pressure sensor can be connected between terminals 30 and 31 instead of the factory-fitted link, in order to provide additional protection for the pump against dry-running. During filtration, a certain maximum time (factory set to 10 seconds, adjustment range 5-60 sec) is allowed after the filtration pump starts running before this contact must close. If the contacts do not close in this time, the filtration pump is switched off and the fault indicator light comes on. This contact is not polled during backwashing.

The terminals carry a safety extra low voltage.

### Connecting the dosing equipment

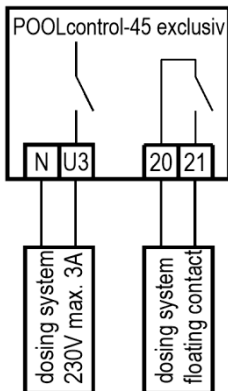

An auxiliary item of equipment running at 230V (e.g. dosing equipment) can be connected to terminal U3. This equipment is switched on together with the filtration pump during filtration.

A volt-free floating relay contact is available between terminals 20 and 21 inside the control unit. This can be used to control additional dosing equipment (contact is closed during filtration).

This contact is rated for a maximum load of 230V/4A.

### Connecting a fault indicator

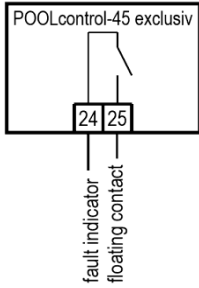

An external fault indicator can be connected to volt-free floating terminals 24 and 25. This contact is rated for a maximum load of 230V/4A.

### Connecting a main drain valve (ECO valve)

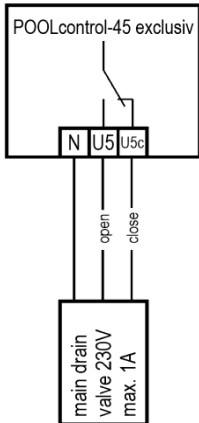

A main drain valve (ECO valve) or a valve for water extraction from the sides of the pool can be connected to terminals U5 and U5c. Connect a 2-way valve to terminals U5 and N. For a 3-way valve, use terminal U5 for "OPEN" and terminal U5c for "CLOSE". This contact is rated for a maximum load of 230V/1A.

For overflow pools with spillway, this valve is opened in ECO mode to minimize evaporation losses.

If this valve is also meant to be opened during backwashing, then the option **Open floor drain during backwashing** must be selected in the configuration menu.

### Connecting a pressure switch

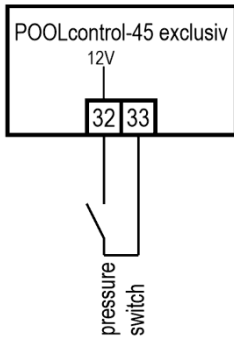

A pressure switch fitted in the pressure line or in the gauge port of the central valve can be connected to terminals 32 and 33. The backwash process starts if the floating contact of the pressure switch remains closed for at least 10 seconds.

The terminals carry a safety extra low voltage.

### Connecting a drain-monitoring switch

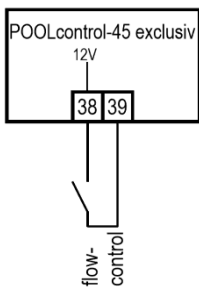

A flow sensor for monitoring the water flow in the drain and triggering an alarm in the event of a fault can be connected between terminals 38 and 39 instead of the factory-fitted link. There are two options available depending on the configuration:.

- Generate a fault indicator if water is flowing while the filter is running;
- Generate a fault indicator if no water is flowing during backwashing.

Time delay: 10 seconds

The terminals carry a safety extra low voltage

### Connecting a shut-off valve (interlock for the 2nd filter)

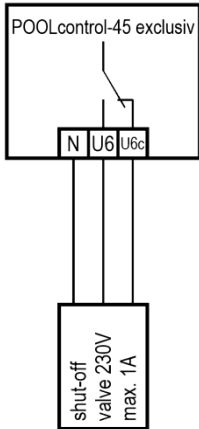

A valve can be connected to terminals U6 and U6c. This facility can be used to isolate the filter while another filter is being backwashed. Operation depends on the configuration. This contact is rated for a maximum load of 230V/1A.

## Temperature sensor

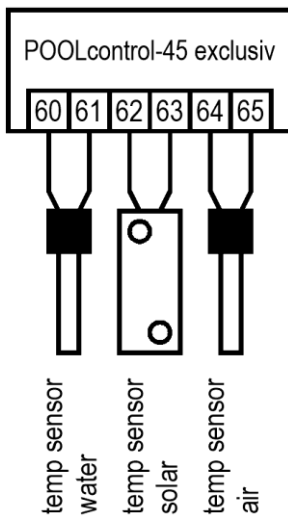

The sensors can be connected either way round (polarity not important).

### Pool temperature sensor

Connect the swimming-pool temperature sensor to terminals 60 and 61. The temperature sensor is supplied as standard with a cable length of 1.5m. If required, this can be extended to a maximum length of 20m using a twin-core cable (min. cross-section 0.5mm<sup>2</sup>). Avoid running the sensor lead close to mains cables to prevent potential interference.

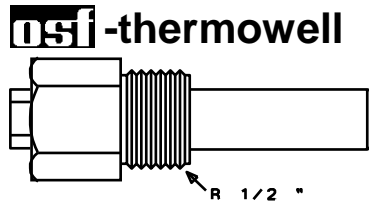

Since precise temperature control can only be achieved with good heat transfer between the temperature sensor and swimming pool water, an **OSI** R1/2" thermowell (part no. 320.020.0003) must be fitted in the piping system.

### Solar temperature sensor

In addition, a solar temperature sensor (part no. 310.000.0033) can be connected to terminals 62 and 63. The temperature sensor is supplied as standard with a cable length of 20m. If required, this can be extended to a maximum length of 50m using a twin-core cable (min. cross-section 0.5mm<sup>2</sup>). **Avoid running the sensor lead close to mains cables to prevent potential interference.** The solar temperature sensor should be fitted at the solar collector output in good thermal contact with the returning water flow. The temperature at the installation position for the temperature sensor must not exceed 80°C.

### Air temperature sensor

An air temperature sensor can be connected to terminals 64 and 65. This sensor is used for controlling the automatic frost protection function. The solar temperature sensor mentioned above, part number 310.000.0033, is suitable for this job. This temperature sensor is also suitable for installing with an indoor pool. In this case, it shows the room temperature in the display.

# Level control

The built-in level control is designed both for overflow pools with spillway and for skimmer pools. The version to be used must be specified when configuring the control unit before use: in the configuration menu select either the option pool with flow-off gutter or pool with skimmer.

## Overflow pool with spillway

**ISI** electrode probes must be used as the level sensors.

The tensile strength of the special cable is high enough for the probes to be suspended by this cable in the overflow balancing tank. It does not matter if the individual probes touch each other. The probes are fixed above the tank using the **ISI** probe holder.

Connect the special cables to a junction box (installed by the customer). A cable must be laid from this junction box to the control unit (e.g. cable NYM-0 7x1.5 mm<sup>2</sup>). The cable must not exceed 30m in length. The cable must not be laid alongside mains power cables.

The probes operate with safety extra low voltage (SELV).

Take special care when fitting the probes to ensure they are connected in the correct order, because the installation will not work if the probes are mixed up.

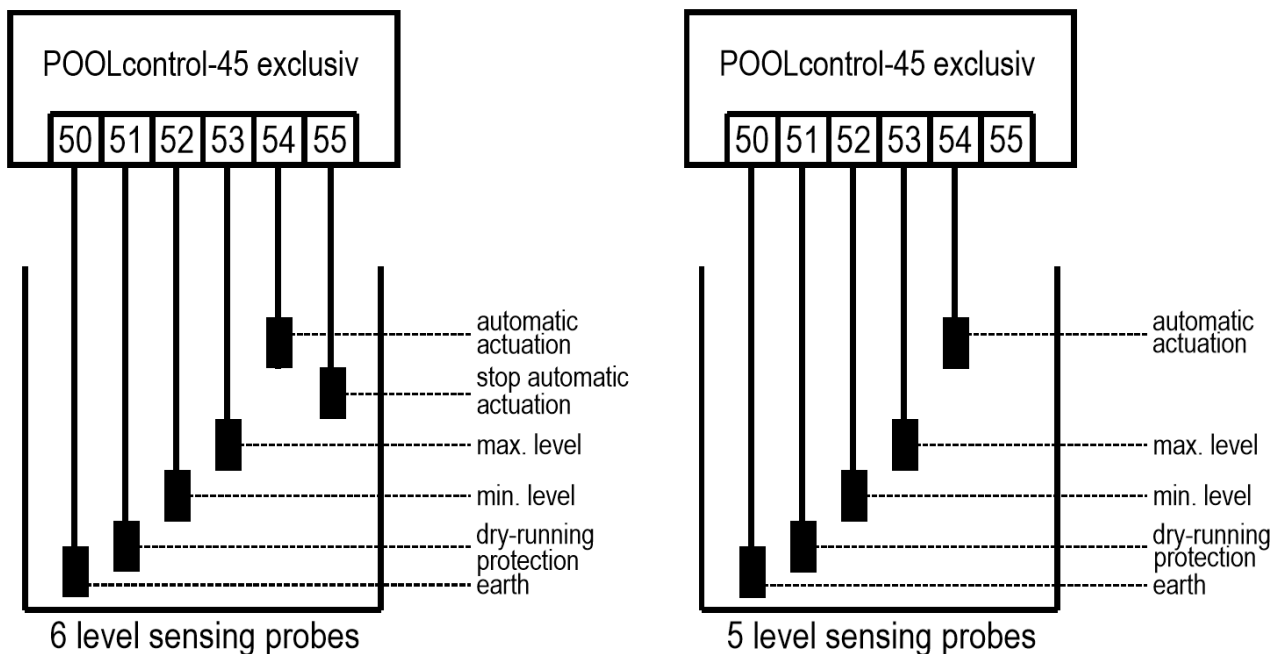

## Operation with 6 probes

### Funktion der einzelnen Tauchelektroden

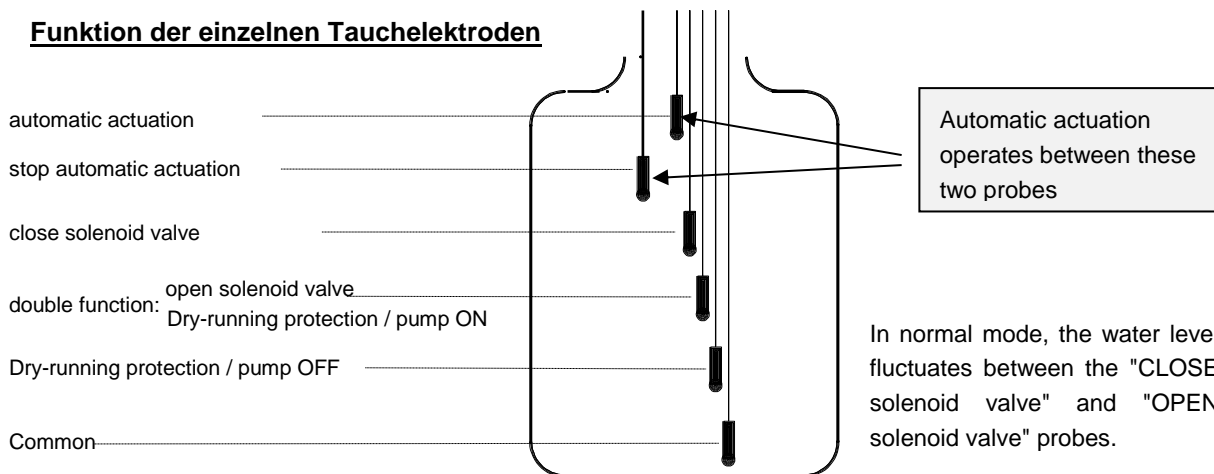

## Operation with 5 probes

### Funktion der einzelnen Tauchelektroden

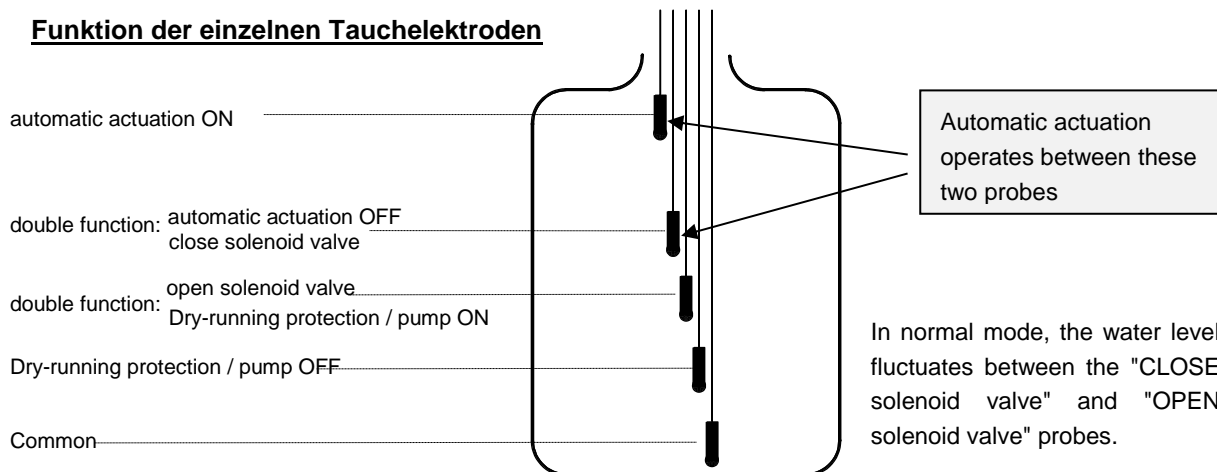

### How level control works for balancing tanks

Level control for balancing tanks performs the following functions:

a. Controlling the water level.

When water is lost from the swimming pool, e.g. through evaporation or backwashing, causing the water level to drop to below the "OPEN solenoid valve" probe (terminal 52), the solenoid valve (terminal U9) opens and the inflowing fresh water causes the water level to rise. As soon as the rising water level reaches the position of the "CLOSE solenoid valve" probe (terminal 53) and touches this probe, the solenoid valve closes the supply of fresh water.

b. Protecting the filtration pump against dry-running.

When water is lost from the swimming pool, e.g. from backwashing, causing the water level to drop to below the "Dry-running protection / pump OFF" probe (terminal 51), the level control system switches off the filtration pump to prevent it being damaged by running without water. As soon as the water level has returned to the height of the "Dry-running protection / pump ON" probe (terminal 52) and touches this probe, the level control system automatically switches the filter control unit back on.

c. Automatic actuation, **operation with 5 probes**

If water displacement in the swimming pool has increased the water level in the balancing tank so that it touches the "automatic actuation ON" probe (terminal 55), the level control system automatically switches on the filtration pump. The water is then pumped back into the pool, avoiding unnecessary loss of precious water. The "automatic actuation ON" probe must be placed a few cm lower than the overspill.

d. Automatic actuation, **operation with 6 probes**.

If water displacement in the swimming pool has increased the water level in the balancing tank so that it touches the "automatic actuation ON" probe (terminal 55), the level control system automatically switches on the filtration pump. The water is then pumped back into the pool, avoiding unnecessary loss of precious water. The "automatic actuation ON" probe must be placed a few cm lower than the overspill. The automatic actuation function is switched off as soon as the water level drops below the "automatic actuation OFF" probe (terminal 54).

### Pool with skimmer

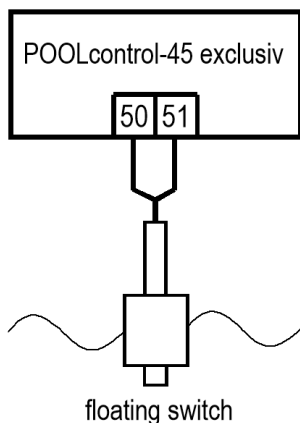

An **tsi** mini float switch must be used as the sensor for skimmer pools. The float switch lead can be extended with a cable (2x0.75mm<sup>2</sup>) of up to 30m in length. Please note that the connection must be absolutely watertight. The float-switch connecting cable must not be laid alongside other current-carrying cables.

The mini float switch operates with safety extra low voltage (SELV). In this operating mode a time delay is automatically enabled in conjunction with the mini float switch. This adjustable time delay prevents over-frequent switching as a result of waves moving the pool water. The delay length can be adjusted in the configuration menu.

Fit the mini float switch on the sliding bracket. Then fasten the fixing rail vertically on the skimmer wall at the approximate height required for the water level. You can then set the water level by moving the sliding bracket up and down the rail. Tighten the screw to fasten the sliding bracket in place. All the parts fit easily inside each other so no great force is needed.

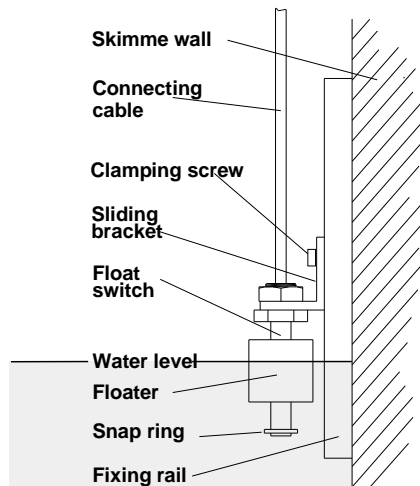

### Level measurement in the standpipe

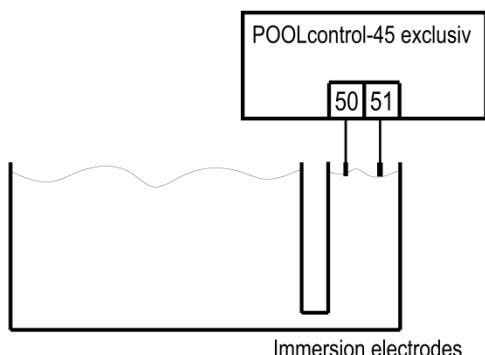

The level can also be measured with the help of 2 immersion electrodes (e.g. 2x 303.000.0011). **These may only be installed in areas in which they cannot be touched from the pool** (e.g. in an external standpipe or in a touch-protected sensor chamber in the skimmer).

The electrodes are operated with safety extra-low voltage (SELV). In this operating mode a time delay is automatically enabled. This adjustable time delay prevents over-frequent switching as a result of waves moving the pool water. The delay length can be adjusted in the configuration menu.

### Use without level control

If you do not want to use the built-in level control, you must select the **No level control** option in the configuration menu.

### Solenoid valve for topping up the water level

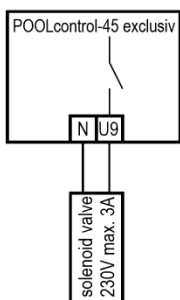

A normally closed solenoid valve must be used for the water intake. This valve must be connected to terminals U9 / N of the control unit. A suitable solenoid valve (R1/2"), part number 1090005804, is available from the **tsi** range.

## Display

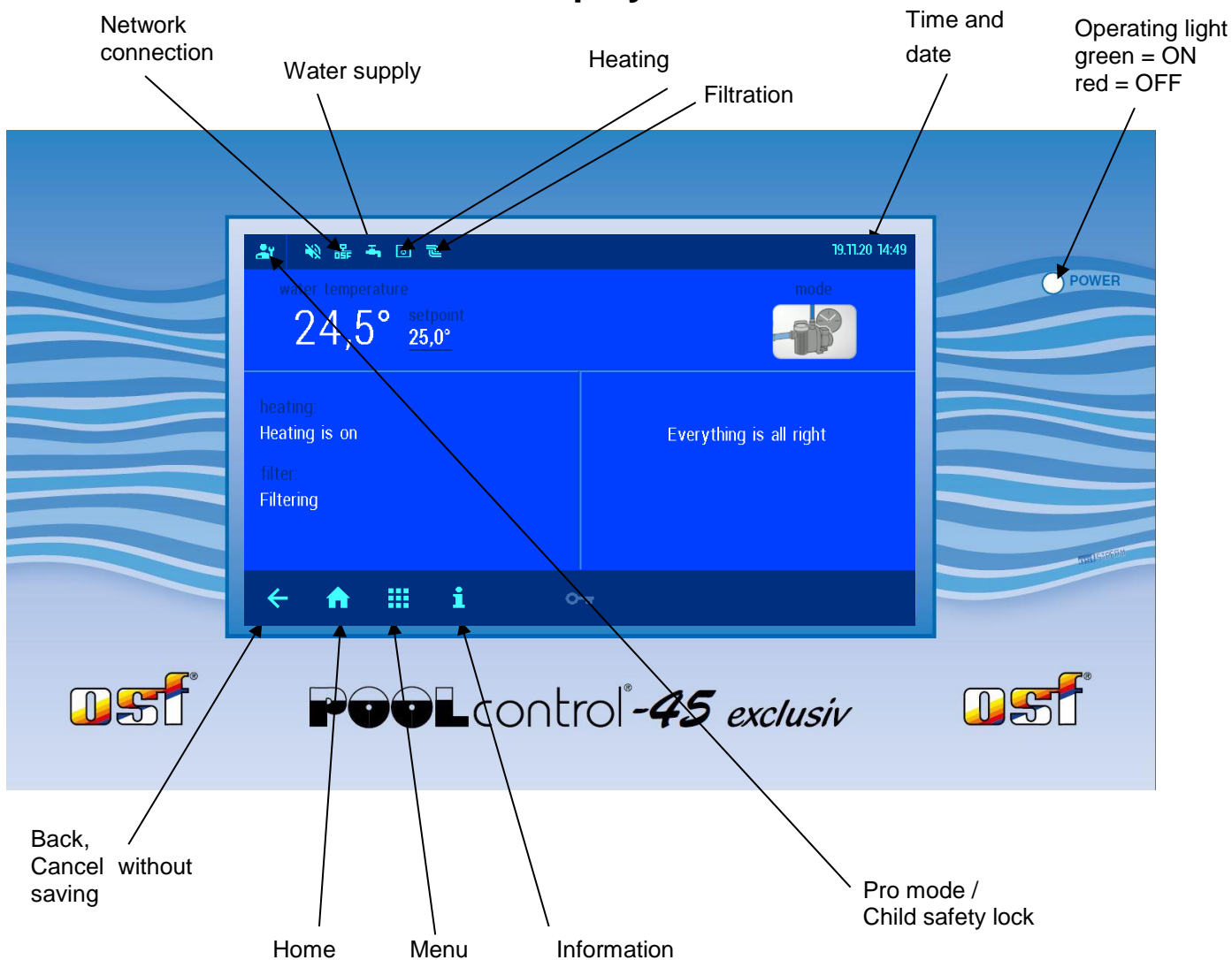

## Operation

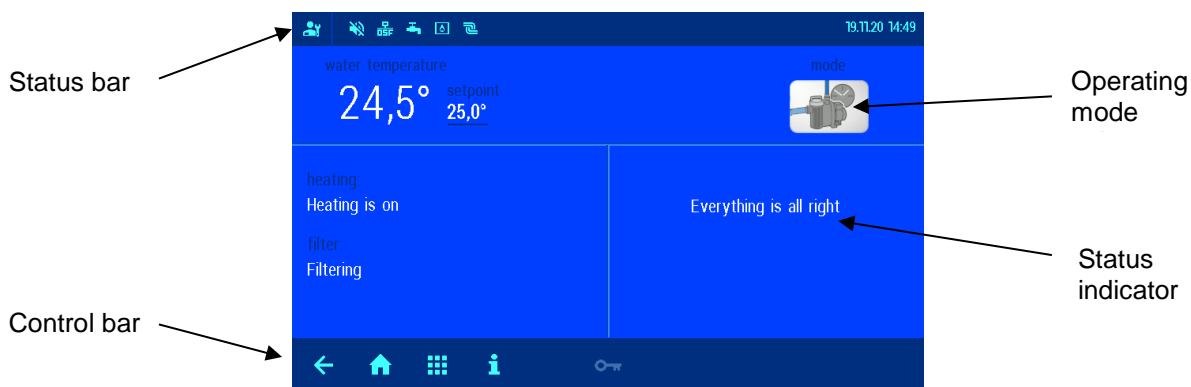

### Switching on the PC-45 exclusiv

When the PC-45 is off, the operating light is red. To switch on the unit, touch any point on the screen for at least 3 seconds.



### Switching off the PC-45 exclusiv

The button for switching off the control unit is located on the "Operating mode" display page. Press the "operating mode" button. Press and hold the power-off button for at least 3 seconds to switch off the PC-45 exclusiv. When the PC-45 is off, the operating light is red.



### Operating mode selection

Tap the operating mode selector. The following operating modes are available:

	<p>Automatic mode. The filtration system is operated under timer control. It is also possible, however, for the solar controller, backwash system and/or level control system to force the filtration pump (if off) to switch on automatically.</p>
	<p>Eco mode (energy saving mode). Depending on how the PC-45 is configured, this mode runs the filtration pump at a lower speed, allows the spillway to run dry or reduces the water temperature.</p>
	<p>Party mode (runs continuously). Switches on the filtration system even though the timer has switched it off. Depending on how the PC-45 exclusiv is configured, Party mode may be timed to switch off again.</p>

### Child safety lock

The icon in the bottom right of the screen indicates the status of the child safety lock.

	<p>Child safety lock is off. Press the key icon to enable the child safety lock</p>
	<p>Child safety lock is on. Press and hold the key icon for 3 seconds to disable the child safety lock</p>

### Pro mode (Service engineer level)

The PC-45 exclusiv provides safeguards against unintentional/unwanted adjustment of important operating parameters.

Those functions that appear in grey on the display can only be used in Pro mode.

	<p>Pro mode enabled</p>
--	-------------------------

To disable the safeguarding function, touch the control bar with your finger and swipe from right to left.

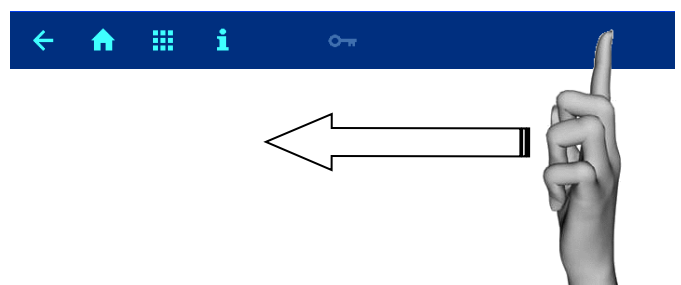

(Note the icon on the left of the status bar)





To enable the safeguarding function, touch the control bar again with your finger and swipe from right to left. (Note the icon on the left of the status bar).

The safeguarding function is re-enabled automatically when no control button has been pressed for an hour.

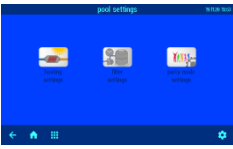
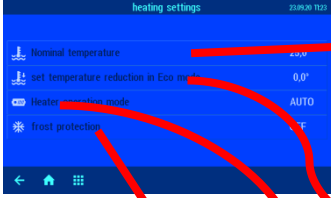
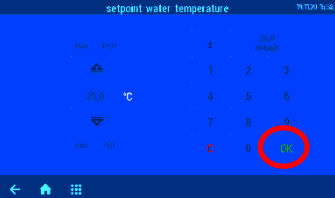
### Heater settings

	<p>Tap the "Menu" button</p> 		<p>Tap the "Heating settings" button</p>
	<p><b>Setting the water temperature</b></p> <p>Use the screen keypad to set the water temperature you require. Then press the "OK" button to save the temperature.</p>		
<p><b>Temperature reduction in Eco mode</b></p> <p>Use the screen keypad to set the water temperature you require. Then press the "OK" button to save the temperature.</p>			
<p><b>Switching the heating on/off</b></p> <p>Use this button to switch between the operating modes "OFF" and "AUTO" (automatic).</p>			
<p><b>Frost protection</b></p> <p>Switch frost protection on / off</p>			

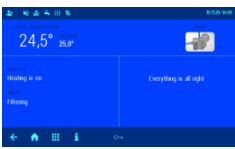
### Settings for the filtration system

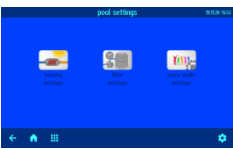
	<p>Tap the "Menu" button</p> 		<p>Tap the "Filter settings" button</p>
---	--	--	---

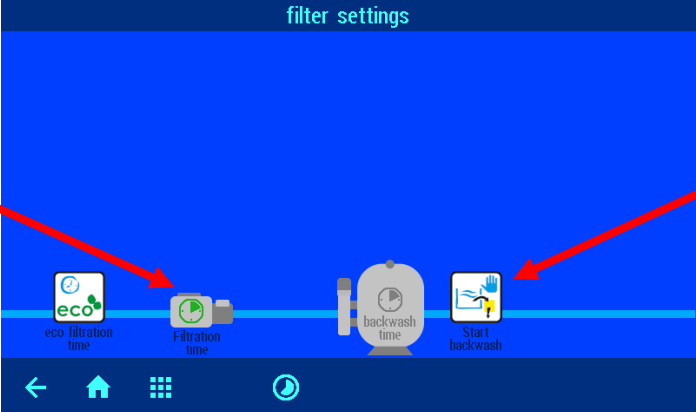

**Filtration timer** → (points to eco filtration time icon)

**Run backwash** → (points to Start backwash icon)

### Automatic – Continuous running – Off



Tap the "Filtration timer" button

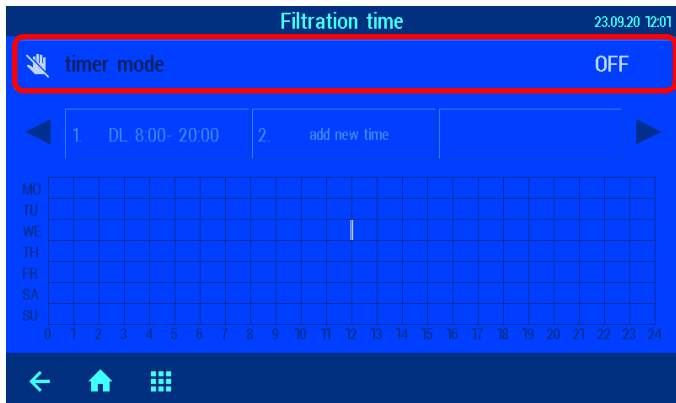

Use this button to switch between the operating modes

ON AUTO OFF.

Note the icon on the right.

ON => runs continuously

AUTO => runs under timer

OFF => switched off

### Programming the filtration timer



Tap the "Filtration timer" button

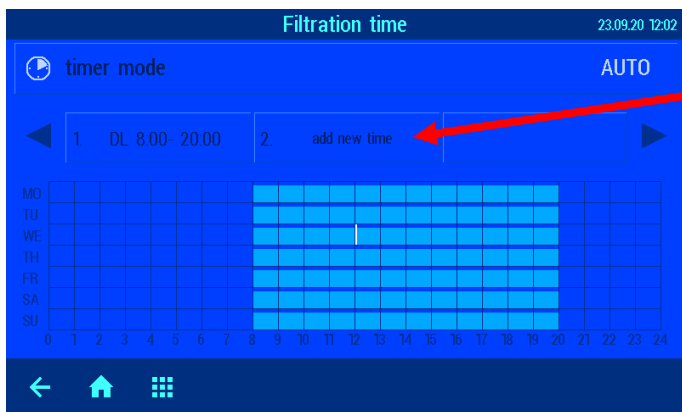

Tap the "Add new time" button

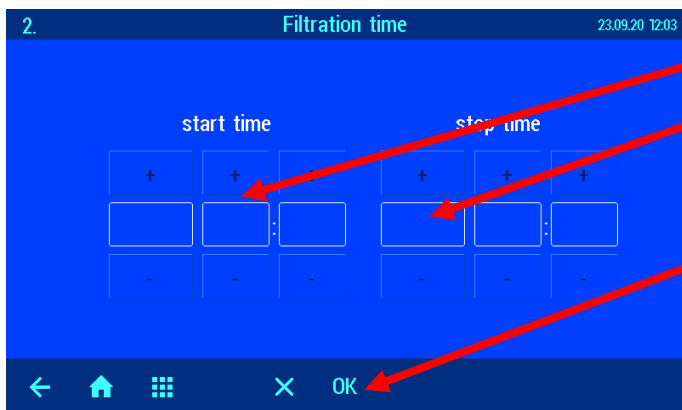

Tap the relevant fields to enter the day of the week, hours and minutes for the switch-on time and switch-off time.

DL stands for daily.

Tap "OK" to save the timer settings.

### Deleting a timer setting



Tap the "Filtration timer" button

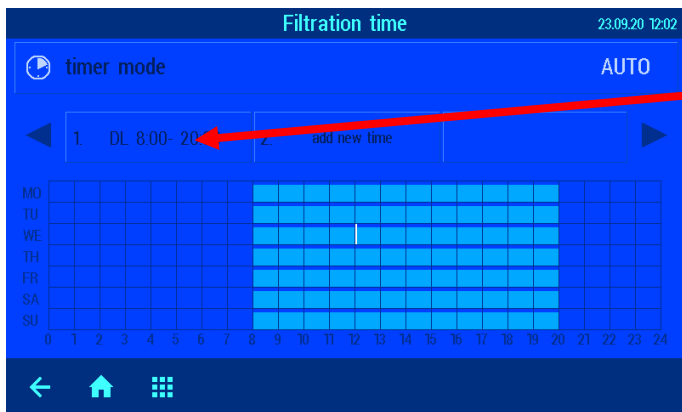

Select the time you want

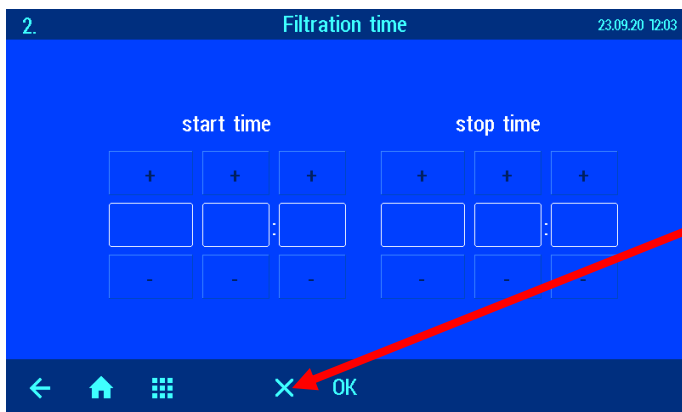

Tap "X" to delete the timer setting. This cannot be undone.

### Checking the timer settings



Tap the "Filtration timer" button

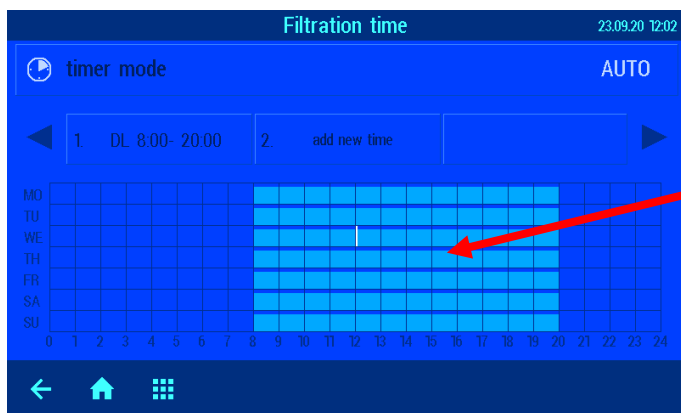

The table shows the programmed switching times for the timer

### Setting the ECO filtration times

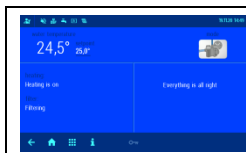

Tap the "Menü" button

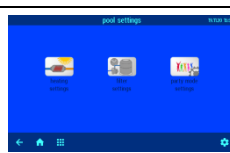

Tap the "Filter settings" button

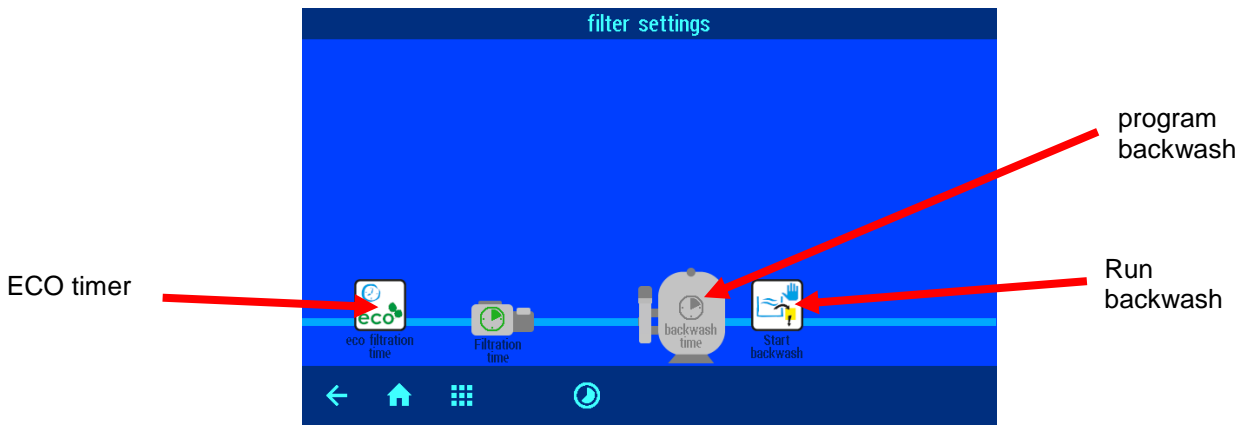

**Automatic – Continuous running – Off**



Tap the “ECO timer” button

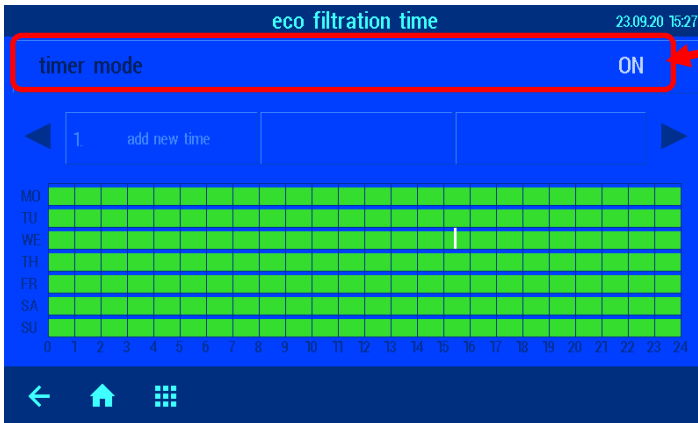

Use this button to switch between the operating modes

**ON** **AUTO** **OFF**.

Note the icon on the right.

**ON** => runs continuously

**AUTO** => runs under timer

**OFF** => switched off

**Entering, editing and deleting ECO timer settings**

The ECO timer can be programmed in the same way as the Filtration timer described above.

**Backwash using slide valves**



**Manual backwash**

Tap the “Run backwash” button on the Filter settings page



**Programming the backwash timer settings**

Tap the “Backwash timer” button on the Filter settings page

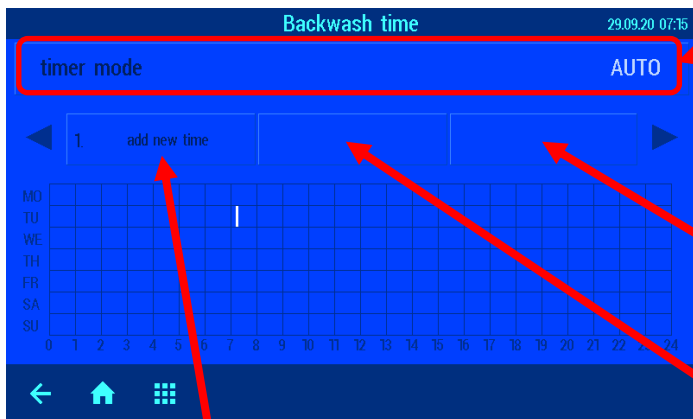

Use this button to switch between the operating modes *AUTO* and *OFF*.  
 Note the icon on the right.

*AUTO* => runs under timer  
*OFF* => switched off

Tap this button to program the day of the week and time for backwashing. You can also select whether backwashing is meant to be performed at a rate of twice weekly, or three times or four times a week.

You can program additional backwash times here

The length of time that backwashing lasts is programmed in the Service settings.

### Setting up Party mode

In Party mode, the swimming pool installation is switched on even though the timer has switched it off. This lets you switch the filtration system to run continuously for a temporary period without having to reprogram the filtration timer.

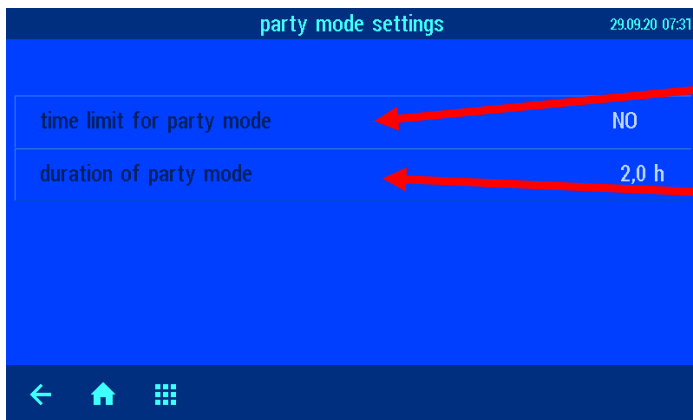
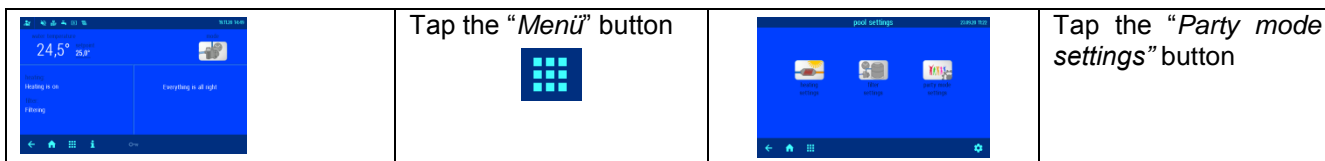

Enable/Disable time limits

Set time length of Party mode

### Fault indicators / Information page

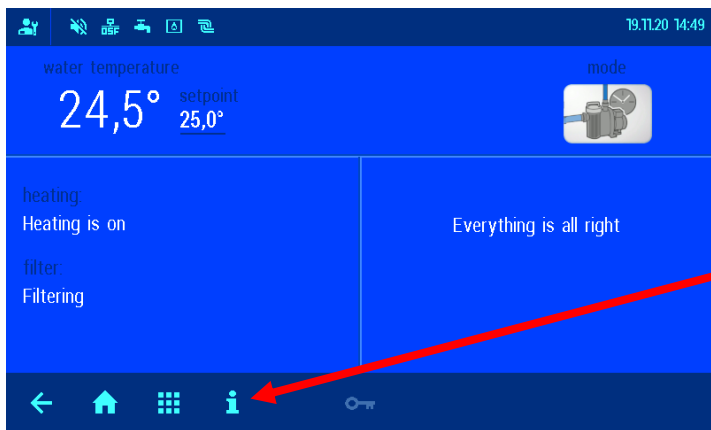

The Information page displays graphically the operating status of the entire filtration system including all sensor readings and any fault indicators. What is displayed depends on the particular configuration.

Press the "i" button

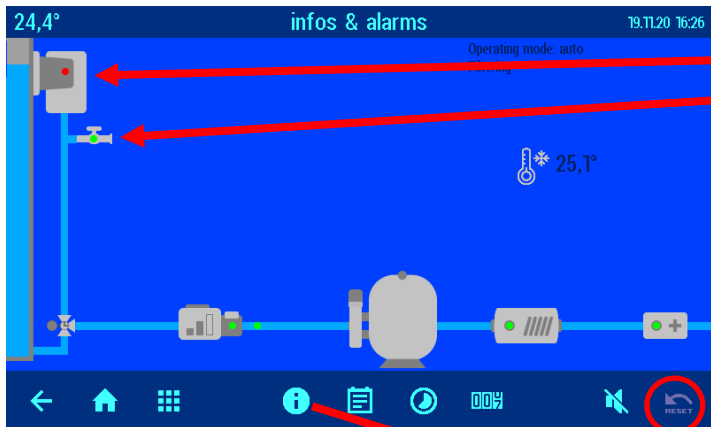

Skimmer

Water supply

#### "Pump disabled" fault indicator

There may be a faulty fuse on the main circuit board.

#### Resetting any fault indicators

The "Reset" button can be used to clear fault indicators, e.g. after the electronic motor protection device has actuated.



Tap the "Information" button

This network name can be changed via the communication server

IP address

ID number for the osf communication server

Software version of each circuit board



#### Log



This screen shows the event log. The PC-45 exclusiv records all events and any changes that have been made at the unit.

#### Operating hours counter



The operating hours for the filtration pump and heating are displayed here alongside the number of backwash cycles, fault indicators, etc.

#### Acoustic alarm



Tapping this icon sets the acoustic alarm to activated or deactivated

## Service settings



Tapping this button in the main screen (bottom right) takes you into the Service area. Only a qualified professional is allowed to make changes to the settings in this area.

- Set the date and time** →
- Network settings** →  
(see below "Connecting to the Internet")
- Add a new device** →
- Perform factory reset** →
- Service settings** →

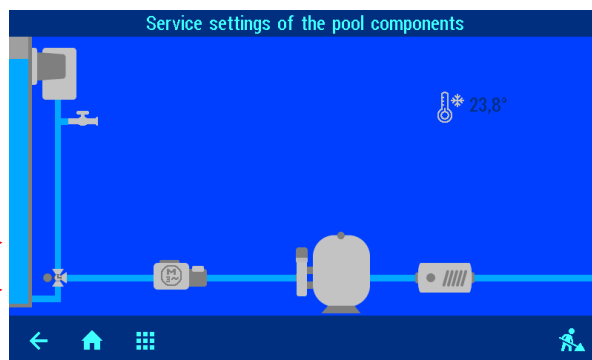

### Alarm settings

In this menu you can set which fault indicators are issued as an acoustic alarm, via email or using the floating relay contact. There are 3 menu pages available for potential alarms.

Tap the text for the alarm you want to edit. A window will then open, where you can select how the alarm is implemented.

Then press the "OK" button to save the setting.

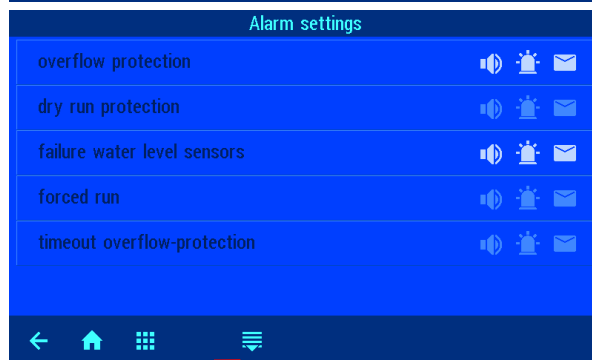

Scroll to next page



Press this "Service settings" button to open the "Service settings for pool components" menu.

### Set the level-control parameters

Tap the "Skimmer" button to switch to the settings level. Here you can set the delay, switching interval (hysteresis) and overflow protection, depending on the given configuration.

### Set motor protection

#### Set the pump startup time

Tap the "Pump" button to switch to the settings level.

### Set the backwash duration

#### Set the rinse duration

Tap the "Filter" button to switch to the settings level.

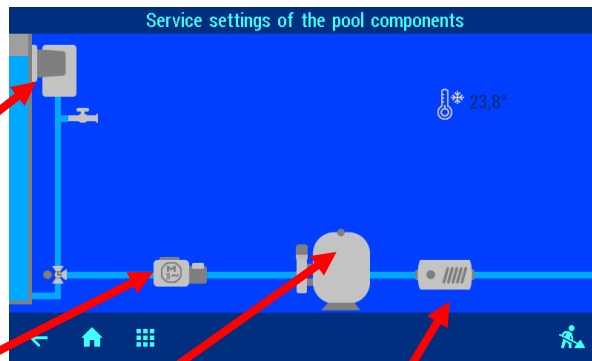

### Set the temperature-control parameters

Tap the "heat exchanger" button to switch to the settings level.

This menu contains 4 pages. The "upper tolerance water temperature" and "lower tolerance water temperature" menu options specify the limits for triggering the alarm.



# Configuring the control unit

## Pro mode

To ensure smooth running of the pool system, when the control unit is first installed it must be configured to suit the actual swimming pool it will be used with. These settings can be altered only in Pro mode, in order to safeguard this configuration from being altered by mistake.



Tapping this button in the main screen (bottom right) takes you into the Service area. Only a qualified professional is allowed to make changes to the settings in this area.



Press the “Service settings” button to open the “Service settings for pool components” menu.



Tapping this button (bottom right) takes you to the “Configuration of hardware” menu.

### Configuring the level control

#### Select the type of level control

In this menu you select the type of level control suitable for the pool. Press the “OK” button to save the setting. The electrical connection to the sensors must be made to suit this setting.

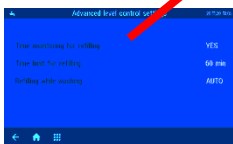

#### Time monitoring for refilling

In this line you can set whether automatic water top-up is stopped after an adjustable maximum time limit. This is a safety feature to prevent overflowing in case the water-level sensor develops a fault.

#### Time limit for refilling

This is where you can set the time limit for the time monitoring option.

#### Refilling while washing

In this line you can set whether:

- water is always topped up when backwashing starts in order to make up for any water loss more quickly;
- topping up with water is disabled during backwashing to avoid loss of pressure;
- topping up with water is regulated automatically according to the water level.

### Configuring the filtration pump

The type of filtration pump must be specified when the control unit is first set up for use. The following options are available:

- three-phase filtration pump
- single-phase filtration pump
- variable speed pump

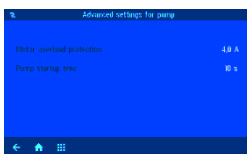

#### Set motor protection

The trip current can be set by pressing the “Motor overload protection” button. Press the “OK” button to save the setting.

*The actual current consumption of the pump is displayed on the “INFO” page.*

Motor protection can only be used with 400V/50Hz and 230V/50Hz filtration pumps connected to terminals U1/V1/W1. Motor protection is not active if the configuration with variable speed pump has been selected.

#### Set the pump startup time

The “pump startup time” button lets you set a delay, which is the time that will elapse after the filtration pump starts before a flow-sensor reading is taken. Press the “OK” button to save the setting.

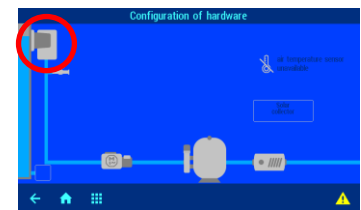

### Configuring the heating

The type of heating system must be specified when the control unit is first set up for use. The following options are available:

- heat exchanger
- solar absorber

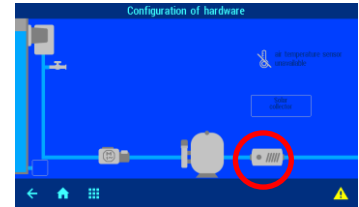
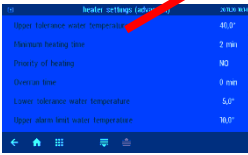

### Setting the heating parameters

There are 3 menu pages available for setting the parameters.

### Configuring the solar heating

The type of heating system must be specified when the control unit is first set up for use. The following options are available:

- heat exchanger
- solar absorber

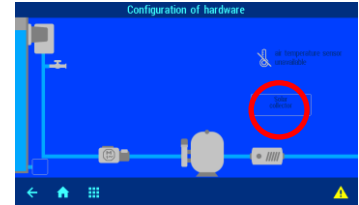
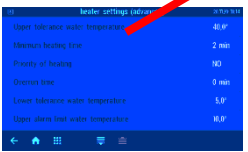

### Setting the heating parameters

There are 3 menu pages available for setting the parameters.

### Configuring the air temperature sensor Frost protection

The task performed by the air temperature sensor must be specified when the control unit is first set up for use. The following options are available:

- air temperature sensor for outdoors
- air temperature sensor for indoors
- no air temperature sensor installed

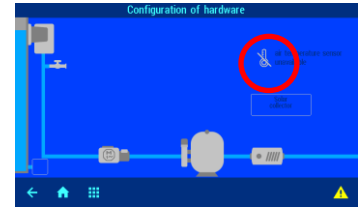

The option "Air temperature sensor for outdoors" is required in order to implement the frost protection function. The temperature reading is displayed in the main screen.

The temperature measured by the "Air temperature sensor for indoors" is displayed in the main screen.

### Configuring the backwashing

The type of backwashing system must be specified when the control unit is first set up for use. The following options are available:

- EUROTRONIK-10 external backwash
- Internal backwash with slide valves
- Manual backwash

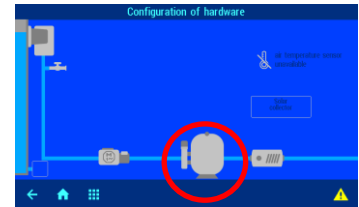
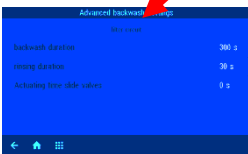
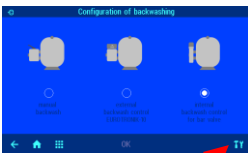

### Setting the backwash period (slide valve)

Tapping this button takes you to the menu for setting the backwash period.

### Setting the rinse period (slide valve)

Tapping this button takes you to the menu for setting the rinse period.

- When rinsing using a 6-way valve, the time are entered directly in the EUROTRONIK.
- If a value is entered for "actuating time slide valves", the filtration system switches off while the valves are adjusted.
- If a main drain valve is installed, it can be opened during backwashing in order to take the water directly from the pool (enable this option in "Settings of floor drain")

### Configuring the main drain valve

When first setting up the control unit for use, it must be specified whether or not a main drain valve is present.

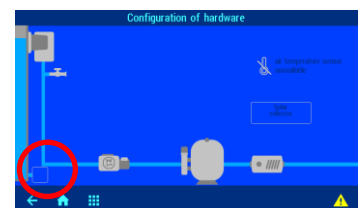

## Connecting a Filter-Control plus to the PC-45 exclusiv

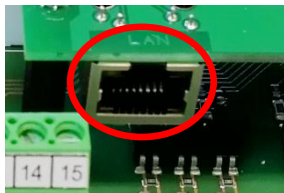

The two control units communicate via an Ethernet local area network (LAN). For the control units to work together correctly, they must both be connected to **the same** local area network.

Use patch cables for the interconnections. Connect one end of the patch cable to the LAN port of the control unit, and the other end to the network switch (or LAN outlet socket) of the local area network.

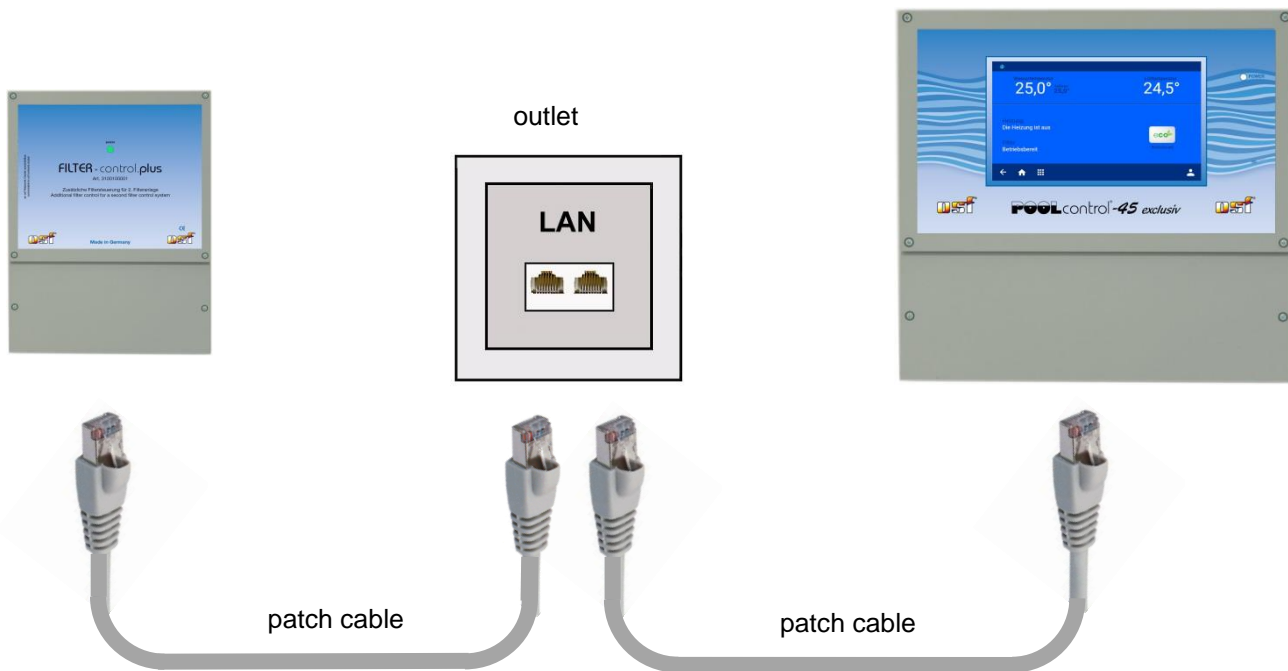
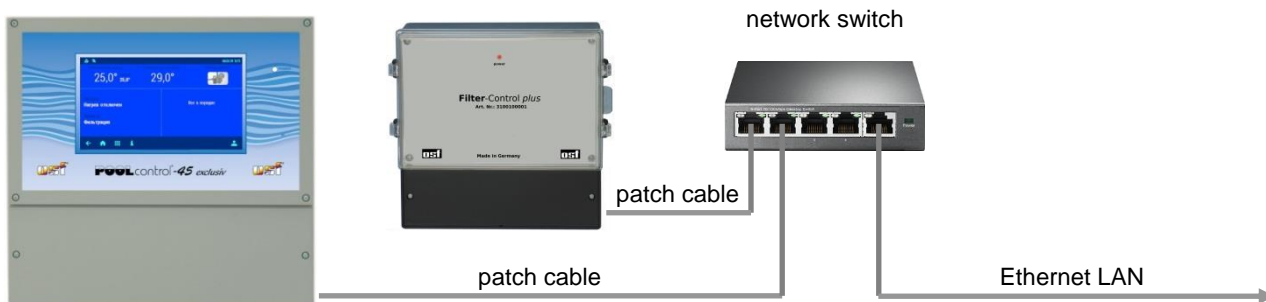

Once you have connected the cables and switched on the control units, a connection between the devices needs to be established in software. You can find further details below in the “Configuration” sections for both units. Once this is done, the two **tsf** units will exchange data via a **local area network**.

# Establishing communication between a PC-45 exclusiv and a Filter-Control plus

## Adding a second filter control panel

Since this task is performed on live control units, it must be carried out solely by an approved electrician.

In the Service menu  press the “*osf network cluster*” button.



 Tapping this icon takes you to a menu in which you can set up communication between the central *PC-45 exclusiv* unit and the *Filter-Control plus* add-on unit.

**Make sure that both units are connected to the LAN.**

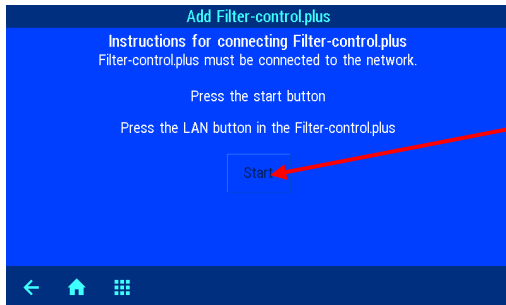

Press the start button to make the PC-45 exclusiv start searching for a Filter-Control plus in the local area network. This search takes several minutes.



During this time, you must press the LAN pushbutton in the Filter-Control plus to establish communication between the two control units. This pushbutton is located in the wiring compartment on the circuit board, on the right between the connecting terminals. When you press the LAN button briefly, the indicator light on the front of the *Filter-Control plus* flashes green to indicate that the mode for “Setting up communication between two controllers” is active. The green light flashes until the connection between the control units is established, although for no longer than 2 minutes. The green indicator light stays on solidly once a connection has been made successfully.

Once this connection is established, the PC-45 exclusiv shows in the display the serial number of the *Filter-Control plus* to which the connection has been made. Both control units are now communicating with each other.

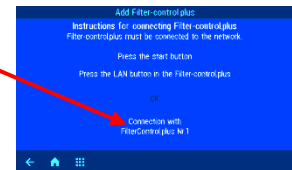

The same procedure used for the first filtration circuit must now be used for configuring the second filtration circuit.

## Disconnecting the *Filter-Control plus* from the *PC-45 exclusiv*

1. In the Service menu, press the “*osf network cluster*” button.

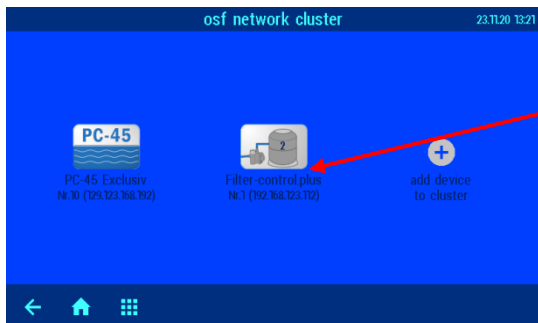

Tap the “Filter Control Plus” button

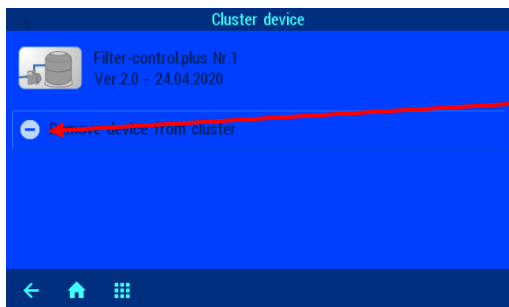

Tapping the button “Remove Filter-Control plus“ in the configuration screen for the second filter removes the connection between the PC-45 exclusiv and Filter-Control plus control units.

### Operation (2nd filter)

The *Filter-Control plus* is operated, configured and adjusted solely via the display for the *PC-45 exclusiv* pool control unit.

Once a connection has been established between the *Filter-Control plus* and *PC-45 exclusiv*, additional menu screens are shown on the display of the *PC-45 exclusiv* pool control unit. This is where the units are configured and their settings altered. The *PC-45 exclusiv* is the central control unit for the entire system and is used for programming the timers for the filtration pumps and for setting the backwash times (slide valves) for both filters.

Connection to osf communication server

### Home screen

Filtration pump 1

Filtration pump 2

The Home screen of the *PC-45 exclusiv* also shows the status bar for the second filter.

- Heating status
- Status of filter number 2 (Filter-Control plus)
- Status of filter number 1 (PC-45 exclusiv)

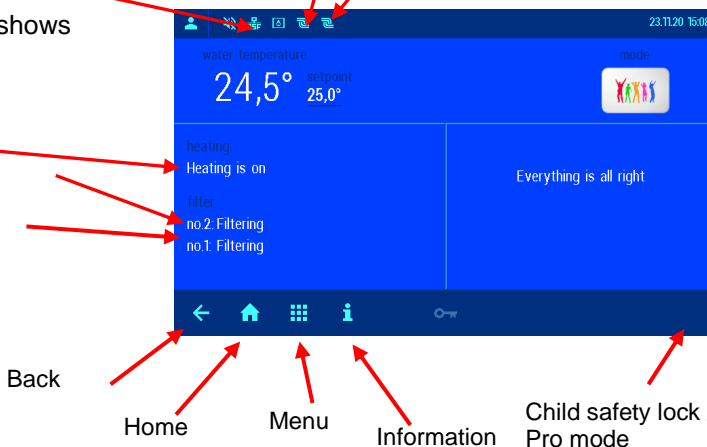

### Backwashing of 2nd filter using slide valves

The “*Filter settings*” menu additionally shows the second filtration circuit and the buttons for filtration and backwashing.

Set the filter times for the second filtration circuit. Eco mode settings apply to the entire system.

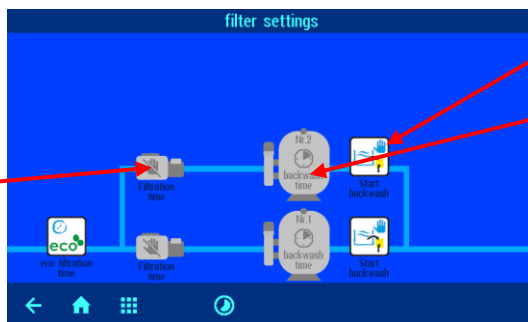

Start backwashing for filter no. 2. Program the backwash start time.

The length of time that backwashing lasts is programmed in the Service settings.

Program the filtration times and backwash start-times for filter no. 2 in the same way as described for the first filter. The time lengths for backwashing and rinsing are programmed in the Service menu in the area for Settings for pool components.

### Information page (2 filters)

The screen contains the shared system information and displays the current status of the pool according to the configuration.

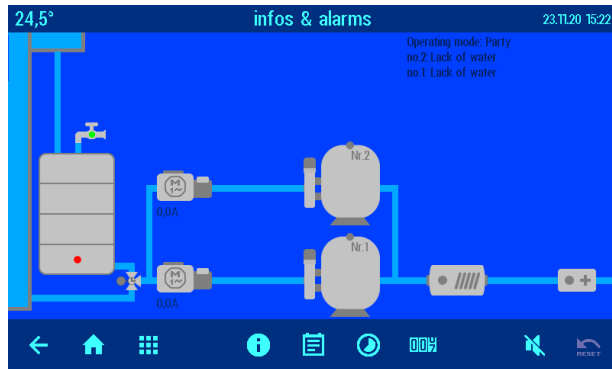
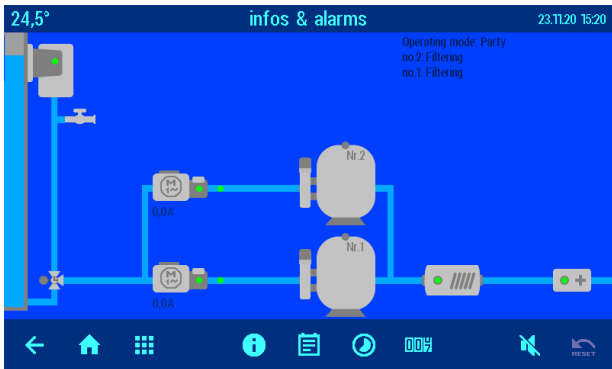

### Service functions (2 filters)

A few Setup menus for service functions have been added to the Home screen.

### Alarm settings for the 2nd filter

Two screens have been added to the “Alarm settings” menu. In this menu, you choose which fault indicators are issued as an acoustic alarm, via email or using the floating relay contact.

### Service settings

Only a qualified professional is allowed to make settings in the Service menu.

In this menu, the settings for all the pool components are customized to suit the selected configuration.

The service settings for the second filtration system are configured in the same way as for the first filtration system. You can find further details in the “Pro mode” section of the instructions for the *PC-45 exclusiv* filter control unit.

## Configuring two filtration systems



Tapping this button opens the configuration menu.

The configuration menu is the core area for making settings for the *PC-45 exclusiv* together with the connected *Filter-Control plus* add-on unit. **The system must be configured correctly for the pool installation to work properly.**

Pressing the button below the two filtration circuits opens the menu for selecting how the two filtration systems are organized.

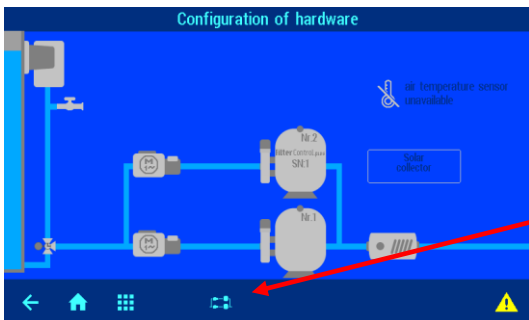

Independent filtration circuits

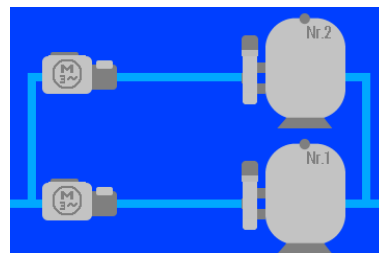
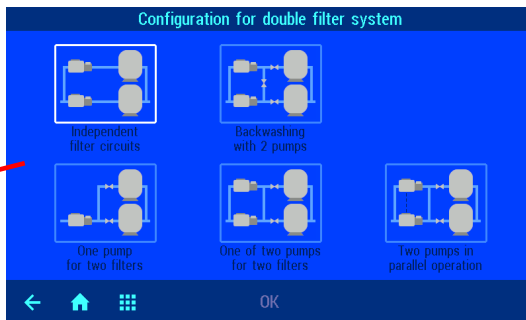

Two-filter system with independent filtration circuits.  
Characteristics:

Each filter is operated with its own dedicated pump. While one filter is being backwashed, the other filtration circuit is stopped.

### *Backwashing using two pumps*

Two-filter system in which one filter is backwashed by both pumps simultaneously.

Characteristics:

When backwashing takes place, the connecting valve opens and the shut-off valve for the other filter closes.

#### *One pump for two filters*

Two-filter system containing one pump.

Characteristics:

When backwashing takes place, a valve shuts off the other filter.

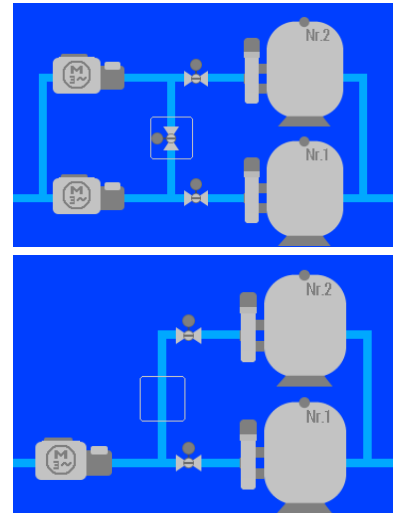

## Internet connection

Access to the Internet is provided via the **tsi** communication server. Use a standard patch cable (network cable) to connect the PC-45 exclusiv to the network outlet socket, the Powerline adapter, the Wireless LAN access point or other suitable installation.

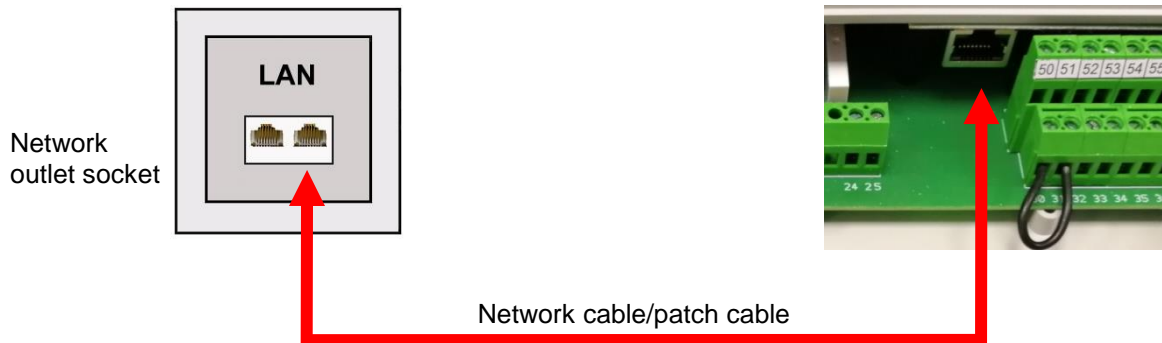

Wait until you have connected the PC-45 exclusiv to an active network socket before switching on the power supply. The **tsi** web server in the PC-45 exclusiv then automatically locates the **tsi** communication server and registers itself with the server databases.

## Using the osf communication server

There are four servers available for communication. They each display different information, designed to suit the needs of different user groups.

<p><b>Mypool.osf.de</b></p>	<p>This server is designed for <b>pool owners</b>. The entire pool system including all web-enabled osf products is displayed on one page on the monitor. The key data for <b>all</b> devices can be retrieved with a <b>single</b> tap of a button.</p>	
<p><b>Service.osf.de</b></p>	<p>This server is designed for <b>pool installers</b>. The top-level page shows <b>all</b> registered pool installations in a clear layout on the monitor. All main parameters and any fault indicators for every customer system are visible at a glance.</p>	
<p><b>Devices2.osf.de</b></p>	<p>This server provides the usual technical view for all connected osf devices.</p>	<p>Geräteübersicht</p>
<p><b>Devices.osf.de</b></p>	<p>For the time being it is still possible to use this familiar server, which has been available for many years. For new installations, however, we recommend the “mypool.osf.de” and “service.osf.de” servers, and “devices2.osf.de”</p>	<p>Geräteübersicht</p>



## Communication server for pool owners

You can access this osf communication server at the address [mypool.osf.de](http://mypool.osf.de)

You must first register as a new user:

Within a few minutes you should automatically receive an e-mail for confirming your identity. (Check your Spam folder if the e-mail does not arrive). Click the activation link in the e-mail to activate your account.

### Registering a new device with the server

Once you have personally registered, you can log in and then register your new device in your user profile. Each web-enabled osf control unit has a DEVICE ID (identification number). This DEVICE ID must be entered in the correct column in order to register the device with the communication server. You can find the DEVICE ID of your device displayed on its Information page (see above). For devices without a display, the ID number appears on an adhesive label. When finished, save the information you have entered.

Imprint Privacy Policy Login user Your devices

Username: \_\_\_\_\_  
 First Name: \_\_\_\_\_  
 Last Name: \_\_\_\_\_  
 E-Mail: \_\_\_\_\_  
 language: de (Deutsch)  
 Password: • \_\_\_\_\_  
 Repeat Password: • \_\_\_\_\_

Nr	Object name	ID #1	ID #2	ID #3	ID #4
1					
2					
3					
4					

Submit

If you press the “Your devices” button, your device is now displayed in your Device panel and can be operated via the communication server:

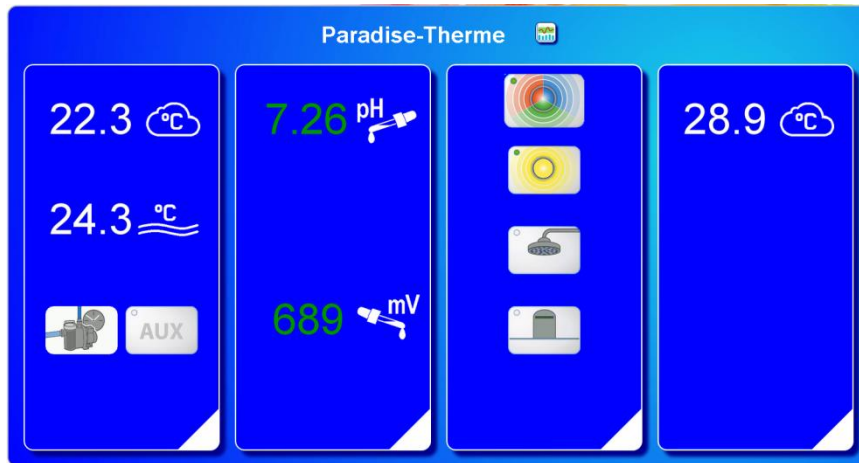

In order to use the communication server, the option "Internet connection via communication server" must be enabled in the control unit itself (default factory setting):

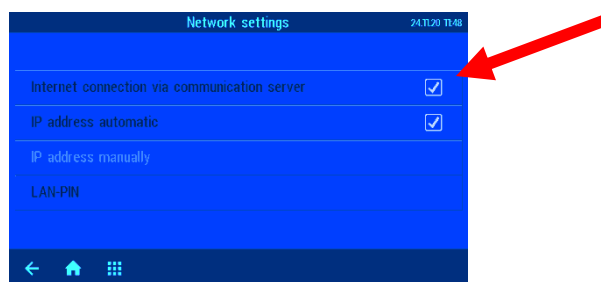

## Communication server for pool installers

You can access this osf communication server at the address [service.osf.de](http://service.osf.de)

You must first register as a new user:

Within a few minutes you should automatically receive an e-mail for confirming your identity. (Check your Spam folder if the e-mail does not arrive). Click the activation link in the e-mail to activate your account.

### Registering a new control unit with the server

Once you have personally registered, you can log in and then register your new device in your user profile. Each web-enabled osf control unit has a DEVICE ID (identification number). This DEVICE ID must be entered in the correct column in order to register the device with the communication server. You can find the DEVICE ID of your device displayed on its Information page (see above). For devices without a display, the ID number appears on an adhesive label. When finished, save the information you have entered.

Imprint Privacy Policy Login user Your devices

Username: \_\_\_\_\_  
 First Name: \_\_\_\_\_  
 Last Name: \_\_\_\_\_  
 E-Mail: \_\_\_\_\_  
 language: de (Deutsch)  
 Password: • \_\_\_\_\_  
 Repeat Password: • \_\_\_\_\_

Nr	Object name	ID #1	ID #2	ID #3	ID #4
1					
2					
3					
4					

Submit

If you press the “Your devices” button, your pool installations are now displayed in your Device panel. This lists the pool installations for all your customers in a table. You can see all the main information at a glance. Fault indicators are highlighted for each pool individually. To display and operate a specific device via the communication server, simply press the associated button for this device:

Connected to the osf communication server

Server connection lost at ...

Customer name

The Paradise-Therme baths contain 4 web-enabled osf devices

Display graphs

Paradise-Therme						
Euromatik.net	OSF			23.2 °C		21.6 °C
MRD-2	OSF	7.26 pH	689 mV		0.52 l/min	
Color-Control.net	OSF					
Silversteam	OSF			28.1 °C		

Mustermann, Königstraße						
PC-45-exclusiv		27.06.2019 10:06		27.6 °C		27.7 °C
Euromatik.net	OSF			23.2 °C		21.6 °C
MRD-2	OSF	18.03.2019 10:15	7.20 pH	699 mV		0.78 l/min

Kundengerät						
PC-40.net	OSF			30.0 °C		
MRD-2	OSF	21.05.2019 03:26	7.23 pH	657 mV		0.00 l/min

In order to use the communication server, the option "Internet connection via communication server" must be enabled in the control unit itself (default factory setting):

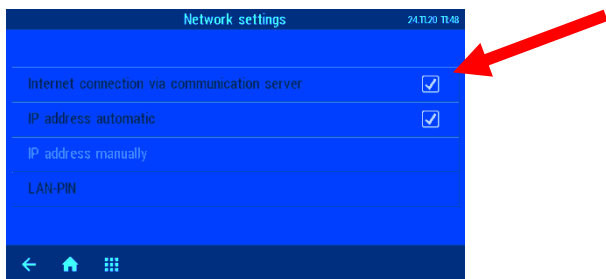

## Communication server with technical view

You can access this osf communication server at the address [devices2.osf.de](http://devices2.osf.de)



You must first register as a new user:

Within a few minutes you should automatically receive an e-mail for confirming your identity. (Check your Spam folder if the e-mail does not arrive). Click the activation link in the e-mail to activate your account.

### Registering a new device with the server

Once you have personally registered, you can log in and then register your new device in your user profile. Each web-enabled osf control unit has a DEVICE ID (identification number). This DEVICE ID must be entered in the correct column in order to register the device with the communication server. You can find the DEVICE ID of your device displayed on its Information page (see above). For devices without a display, the ID number appears on an adhesive label. When finished, save the information you have entered.

Imprint Privacy Policy Login user Your devices

Username: \_\_\_\_\_  
 First Name: \_\_\_\_\_  
 Last Name: \_\_\_\_\_  
 E-Mail: \_\_\_\_\_  
 language: de (Deutsch)  
 Password: • \_\_\_\_\_  
 Repeat Password: • \_\_\_\_\_

Nr	Object name	ID #1	ID #2	ID #3	ID #4
1					
2					
3					
4					

Submit

Your device is now displayed in your Device panel and can be operated via the communications server:



In order to use the communication server, the option "Internet connection via communication server" must be enabled in the control unit itself (default factory setting):

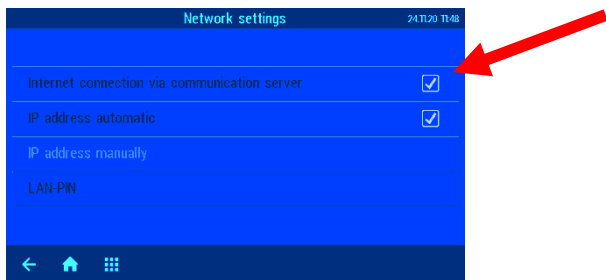

### Changing the PIN (password)

The PC-45 exclusiv contains 2-level password protection for access via the LAN. The User PIN lets you operate the control unit and adjust the essential main functions. The Service PIN is needed to perform service functions and to change settings at the Service level. The following PINs are factory-set:

- User PIN: 1234

- Service PIN: 5678

The PC-45 exclusiv must be connected to the Internet in order to be able to change the PINs. You make the change to a PIN via the WEB interface of the communication server.

### Assigning a new PIN

1. Log in as usual to the communication server
2. Then log in with the Service PIN
3. In the Home page, press the “*menu*” button
4. In the main menu, press the  button

5. In the Service menu, press the “*Network settings*” button

6. Scroll down 2 pages by pressing the  button

7. You can now assign new values to each PIN

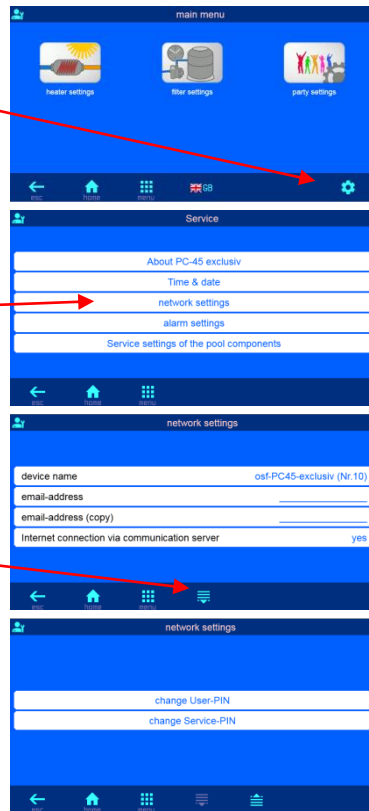

**Make sure you make a note of the PINs!**

## Naming the unit Entering an e-mail address

In order to be able to identify different control units during online access, each osf device has a facility for assigning a name.

The PC-45 exclusiv is able to send any fault indicator messages via e-mail. The control unit must be connected to the Internet for this feature to work. You enter the relevant e-mail addresses (2 maximum) via the WEB interface of the communication server.

### Entering an e-mail address Assigning a name

1. Log in as usual to the communication server
2. Then log in with the Service PIN
3. In the Home page, press the “*menu*” button
4. In the main menu, press the  button

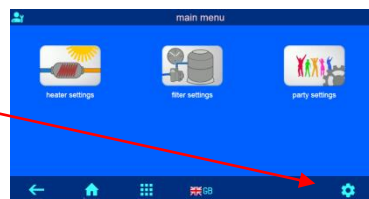

- In the Service menu, press the "Network settings" button

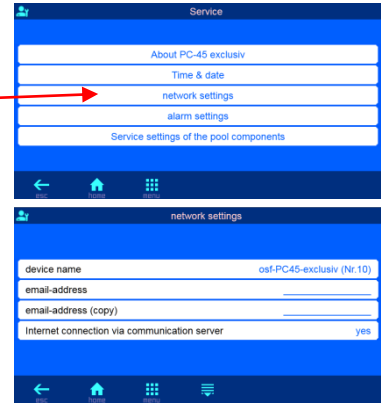

- You can enter the name of the unit and the e-mail addresses here

## Update

The PC-45 exclusiv has a software update facility. The PC-45 exclusiv must be connected to the Internet for updating to work. You can perform the update via the WEB interface of the communication server.

### Checking for updates

You can use this function to check whether an update is available for your device.

- Log in as usual to the communication server
- Then log in with the Service PIN
- In the Home page, press the "menu" button

- In the main menu, press the  button

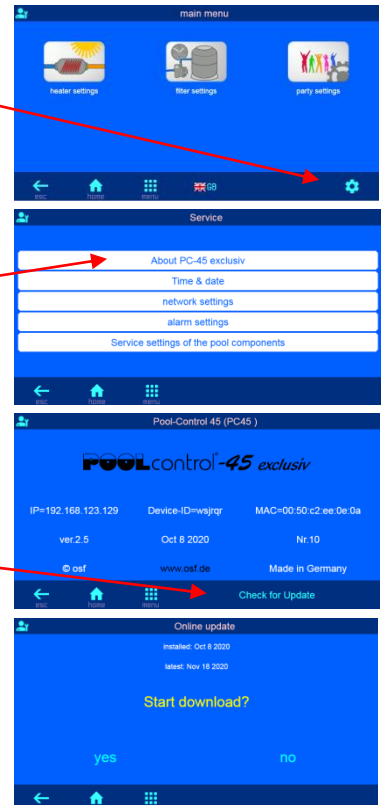

- In the Service menu, press the "About PC-45 exclusiv" button

- In the Service menu, press the "Check for Update" button

- You can now start the download and install the update



## Interfacing with building automation systems

The Pool Control-45 exclusiv contains an HTTP web server, which is designed to allow the control unit to be operated using any web browser from any web-enabled terminal.

The HTML pages generated by this web server can also be accessed by a building automation system and can be interpreted for display on EIB visualization devices. For the purpose of controlling the Pool Control-45 exclusiv, the building automation system can generate IP messages, in the same way as they would be generated by a web browser when you click on controls on the HTML pages. In other words, the building automation system must emulate a web browser.

Instead of using directly the predefined HTML pages designed by **ISI** for displaying on web browsers, you (as user) can also design your own control file to obtain the data you require in "custom" form, and save this file on the SD card in the Pool Control-45 exclusiv. This means that the interface to the building automation system is then unaffected by potential design changes to the **ISI** HTML pages.

This control file must be saved as an ASCII text file with the extension ".HTM" in the "HTML" folder on the SD card. The file name must not exceed 8 characters in length. Although it has the "HTM" extension, this file need not necessarily be a valid HTML file, but can be formatted to suit the requirements of the building automation system.

This control file can contain variables in the format "\$\$nnnn", which the web server then replaces with the data that is currently valid. A list of available variables appears at the end of this document.

A control file "ISTWERTE.HTM" containing the following:

```
Water temperature: $$0100 °C
Solar temperature: $$0101 °C
Air temperature: $$0102 °C
$$0015
```

would, on opening "<http://xxx.xxx.xxx.xxx/istwerte.htm>", return the following text for example:

```
Water temperature: 24.3 °C
Solar temperature: 36.8 °C
Air temperature: 22.4 °C
Filter running
```

These control files can also be used selectively to read specific datapoints, e.g. "WTEMP.HTM" containing the following:

```
$$0100
```

returns

```
24.3
```

In order to make changes to data in the control unit from the building automation system, the building automation system must emulate sending an HTML form. This is done by a URL invocation in the form "<http://xxx.xxx.xxx.xxx/modify?nnnn=data>", where nnnn is the number of the variable to be changed, and data represents the data to be stored.

Before the building automation system can change any variables, it must first log in by sending a valid PIN number to the variable 0003:

["http://xxx.xxx.xxx.xxx/modify?0003=dddd"](http://xxx.xxx.xxx.xxx/modify?0003=dddd), where dddd is the user PIN configured in the unit.

Variables can be set after successful login, e.g. set the required temperature to 28°C:

["http://xxx.xxx.xxx.xxx/modify?0110=28.3"](http://xxx.xxx.xxx.xxx/modify?0110=28.3).

Afterwards, the building automation system should log out by writing to the variable 0003 again with any invalid value:

["http://xxx.xxx.xxx.xxx/modify?0003=0000"](http://xxx.xxx.xxx.xxx/modify?0003=0000)

The most important operating data can also be read out in compact JSON format using the predefined "INFOS.JSON" file. This standardized file format can be processed by many control systems.

Example:	Description:
<pre>{ "device": "PC-45 exclusiv", "devnum": "6", "softfw": "28", "wtival": "26.0\u00b0", "wt sval": "25.0\u00b0", "atival": "44.7\u00b0", "cover": {"open": "0", "closed": "0"}, "modest": "1", "pump1st": "0", "pump2st": "-1", "pump3st": "-1", "language": "de", "acwday": "Donnerstag", "actime": "11:52", "acdate": "22 Apr 2021", "isodat": "2021-04-22T11:52:46+01" }</pre>	<p>device name</p> <p>serial number</p> <p>Firmware version</p> <p>current water temperature</p> <p>desired water temperature</p> <p>current air temperature</p> <p>Limit switches of the pool cover</p> <p>current operating mode of the pool</p> <p>current speed level of the 1st filter pump</p> <p>current speed level of the 2nd filter pump</p> <p>current speed level of the 3rd filter pump</p> <p>language of the web interface</p> <p>current day of the week</p> <p>current time</p> <p>current date</p> <p>time stamp in ISO format</p>

Variables available for communication with the building management system (as of May 7th, 2021):

No.	Name	Read/ Write	Format	Value range	Info
0003	user PIN	W	„#####“	„0000“ - „9999“	Login
0013	Status text heating	R	ASCII text		
0015	Status text filtration	R	ASCII text		
0019	Operating mode filtration	W	ASCII	„i1“ bis „i3“	„i1“: ECO mode „i2“: Auto mode „i3“: Party mode
0026	Backwash filter 1	W	ASCII	'i'	Start/Stop
0027	Backwash filter 2	W	ASCII	'i'	Start/Stop
0028	Backwash filter 3	W	ASCII	'i'	Start/Stop
0100	Water temperature	R	„##.##“		
0101	Solar temperature	R	„##.##“		
0102	Air temperatuer	R	„##.##“		
0110	Setpoint water temperature	R/W	„##.##“	„00.1“ - „40.0“	
0123	Frost protection	W	ASCII	'0', '1', 'i'	0: OFF 1: ON i: toggle
9000	Collective fault message	R	'#'	'0' - '1'	'0'=Off, '1'=On
9013	Status variable heating	R	'#'	'0' - '3'	'0'=Off '1'= Heat exchanger '2'= Solar heating
9019	Operating mode filtration	R	'#'	'0' - '3'	'0': OFF '1': ECO '2': AUTO '3': PARTY
9551	Speed filter pump	R	'#'	'0' - '3'	'0': OFF '1': ECO '2': NORMAL '3': BACKWASH
9552	Speed filter pump 2	R	'#'	'0' - '3'	'0': OFF '1': ECO '2': NORMAL '3': BACKWASH
9553	Speed filter pump 3	R	'#'	'0' - '3'	'0': OFF '1': ECO '2': NORMAL '3': BACKWASH

# Wiring diagram

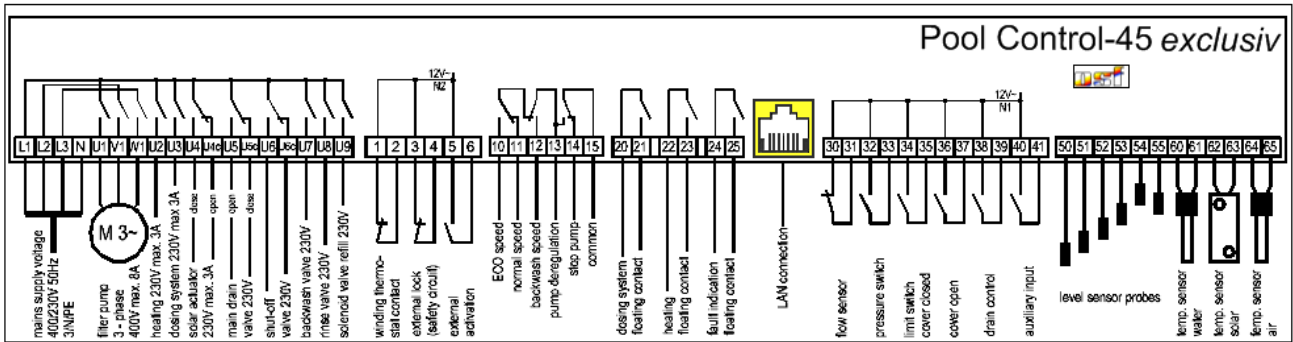

*Relax and enjoy your swimming pool!*

Further information can be found on the Internet at the following address:

<https://osf.de/download/documents/documents.php?device=PC-45-exclusiv>



**OSI** Hansjürgen Meier  
 Elektrotechnik und Elektronik GmbH & Co KG  
 Eichendorffstraße 6  
 D-32339 Espelkamp  
 E-mail: [info@osf.de](mailto:info@osf.de)  
 Internet: [www.osf.de](http://www.osf.de)

Subject to changes **OSI** 06/2021